

# Courtroom Technology Design Guide







## TABLE OF CONTENTS

|                         |    |
|-------------------------|----|
| Introduction            | 01 |
| The Crestron Difference | 02 |
| Build                   | 02 |
| Deploy & Manage         | 04 |
| Experience              | 05 |
| GSS Partner Program     | 06 |
| District Courtroom      | 08 |
| County Courtroom        | 24 |
| Civil Courtroom         | 34 |
| Simple Courtroom        | 44 |
| Jury Selection Room     | 52 |
| Judges' Chambers        | 62 |





## INTRODUCTION

For more than 45 years, Crestron has delivered technology solutions that simplify, modernize, and enhance communications and proceedings in courtrooms, increasing jury engagement, while decreasing trial costs. Our secure, scalable, easy-to-deploy solutions are thoughtfully designed to help you meet the wide range of operational needs of every type of courtroom, including hybrid environments, as well as your meeting and training spaces.

- Native Microsoft Teams® or Zoom Rooms™ video conferencing, plus support for any conferencing platform, optimizes communication and collaboration
- Scalable audio, video, and KVM distribution ensures instantaneous, flawless content delivery everywhere you need it
- Intuitive user interfaces deliver a simple, consistent experience in every courtroom
- Cloud-based monitoring and management platform speeds technology deployment and increases uptime
- Advanced room scheduling helps you keep operations running smoothly and efficiently

All of our products are designed to work together as a complete secure system, rather than a collection of unrelated parts housed in technology silos. That means just one number for you to call for all service and support.



## The Crestron Difference

### Build

Take advantage of our free design services or work with one of our dealers or consultants. Either way, you can count on courtrooms in which every voice, visual, or piece of evidence is clearly seen and heard, every time, no matter where it's presented; at the bench, podium, or from the jail.

### Crestron Flex video conferencing solutions

With a native Microsoft Teams or Zoom Rooms experience and BYOD support for any conferencing platform, Crestron Flex solutions give you the ability to bring remote participants into the courtroom with just a single touch. From expert witness testimony, to remote arraignment hearings, your courtrooms will seamlessly blend in-person and remote participation.

### DigitalMedia™ 4K video, audio, KVM, and USB distribution platform

Everything people see, hear, and interact with in courtrooms – evidence presentation and witnesses' testimony – is of paramount importance. With DigitalMedia, you have complete control over who sees or hears what content and when. And it's all delivered securely and flawlessly, down to the last pixel.

### AirMedia® wireless content presentation

Digital content can come from anywhere: a laptop, tablet, or mobile device. Leveraging your secure network, and with support for every OS, AirMedia makes it simple and safe. Just follow the simple on-screen instructions. No plugs, cables, or adapters needed.







## Deploy and Manage

Technology evolves quickly. The ability to simplify and speed deployment and updates, as you remotely monitor performance and respond to issues in real-time, is critical to maintaining a smoothly running operation.

### XiO Cloud® technology deployment, monitoring, and management platform

Every moment matters in the courtroom, so your technology must work. And if it doesn't, the issue needs to be resolved as rapidly as possible. With the award-winning XiO Cloud platform, you can:

- Efficiently pre-configure and deploy new technology at scale
- Silently push out updates to ensure your courtrooms are secure and running optimally
- Monitor all your technology in real-time from within your courthouse or district
- Detect and proactively resolve issues – often before they become issues
- Gather usage data to help make smarter decisions

## Experience

Courtroom dockets are packed every day. There's no time to waste figuring out how to get the technology to work. Crestron technology adapts to the way you work and integrates seamlessly with the technology you're already using. The end result is an intuitive and consistent experience in every courtroom, so you can get right down to business.

### Touch screens

Court proceedings have a well-defined process and workflow. Crestron touch screens give you the ability to provide exactly the right control to those who need it. Route content to displays, mute microphones, bring in remote participants, and more.

### Room scheduling

Crestron room scheduling drives efficiency by allowing you to locate and schedule available rooms with ease. Book courtrooms, meeting spaces, and training areas from your desktop or on the go from your mobile device. Touch screens and illuminated hallway signs outside each room provide a convenient touch point to schedule ad-hoc meetings, view room schedules, or to simply find your meeting.

**Crestron technology solutions are deployed in thousands of courtrooms across the globe: Supreme, District, Court of Appeals, County, Civil, Circuit and Bankruptcy.**



## Government Support Services Partner Program

We understand time is of the essence for our government partners. Our Government Support Services (GSS) Partner Program will never leave you waiting.

- Dedicated Partner Manager will guide you through the design, specification, and procurement stages to ensure seamless system implementation
- Direct RMA, including Advance Replacement on eligible Crestron products during warranty period<sup>1,2</sup>
- Immediate access to Crestron software, application diagrams, and more at [crestron.com](http://crestron.com)
- Access to Crestron Technical Institute (CTI) online and in-classroom training curriculum
- Direct, dedicated, 24/7/365 technical support hotline at 855.445.6097
- Direct, dedicated technical design assistance at 800.237.2041
- Standard three year warranty extended to five years<sup>1,2</sup>

<sup>1</sup> Subject to the terms of Crestron's warranties and terms and conditions of sale

<sup>2</sup> Crestron Flex conference systems excluded





## DISTRICT COURTROOM

### TOTAL SOLUTION

#### Bill of Materials

| Qty | Model Number        | Description   |
|-----|---------------------|---|
| 1   | AM-3200             | AirMedia® Presentation System 3200  |
| 1   | AMP-8075            | 8-Channel Power Amplifier   |
| 1   | CP4N                | 4-Series™ Control System  |
| 1   | DGE-100             | Digital Graphics Engine 100   |
| 1   | DMF-CI-8            | DigitalMedia™ Card Chassis  |
| 2   | DM-DGE-200-C        | Digital Graphics Engine 200   |
| 28  | DM-NVX-360          | DM NVX® Network AV Encoder/Decoder  |
| 5   | DM-NVX-360C         | DM NVX® Network AV Encoder/Decoder Card   |
| 1   | DM-NVX-DIR-80       | DM NVX Director® Virtual Switching Appliance                                    |
| 7   | FT2-500-MECH-PTL-B  | FlipTop™ FT2 Series Cable Management System                                     |
| 7   | FT2A-CBL-PT-4K-HD   | Pass-Through Cable for FT2 Series   |
| 7   | FT2A-CBL-PT-CAT6    | Pass-Through Cable for FT2 Series   |
| 2   | FT2A-PLT-BLANK-10   | FlipTop™ FT2 Series Cable Management System Blank Plate                         |
| 2   | FT2A-PLT-PT-10      | FlipTop™ FT2 Series Cable Management System Cable Pass-Through Plate            |
| 7   | FT2A-PWR-US-1-BASIC | AC Power Outlet Module for FT2 Series   |
| 12  | SAROS IC8T-W-T-EACH | Saros® 8" 2-Way In-Ceiling Speaker  |
| 5   | TS-1070-B-S         | 10.1 in. Tabletop Touch Screen  |
| 2   | TSD-2220-B          | 21.5" HD Touch Screen   |
| 1   | TSS-1070-B-S-LB KIT | 10.1" Room Scheduling Touch Screen  |
| 1   | UC-C100-T           | Crestron Flex Video Conference System Integrator Kit for Microsoft Teams® Rooms |
| 1   | UC-FLEXCARE-C       | Premium Crestron Flex Support   |

Full-featured courtroom with evidence presentation and videoconferencing.

#### System Features

FlipTop touch screen control at attorney tables and lectern

Full-featured switching design using DM NVX AV-over-IP and DM NVX Director® virtual switching appliance

Wireless presentation capability

Multiple display support

Remote video conferencing capability

Touch screen control at judge, attorneys, deputy/clerk, and lectern locations

Room scheduling

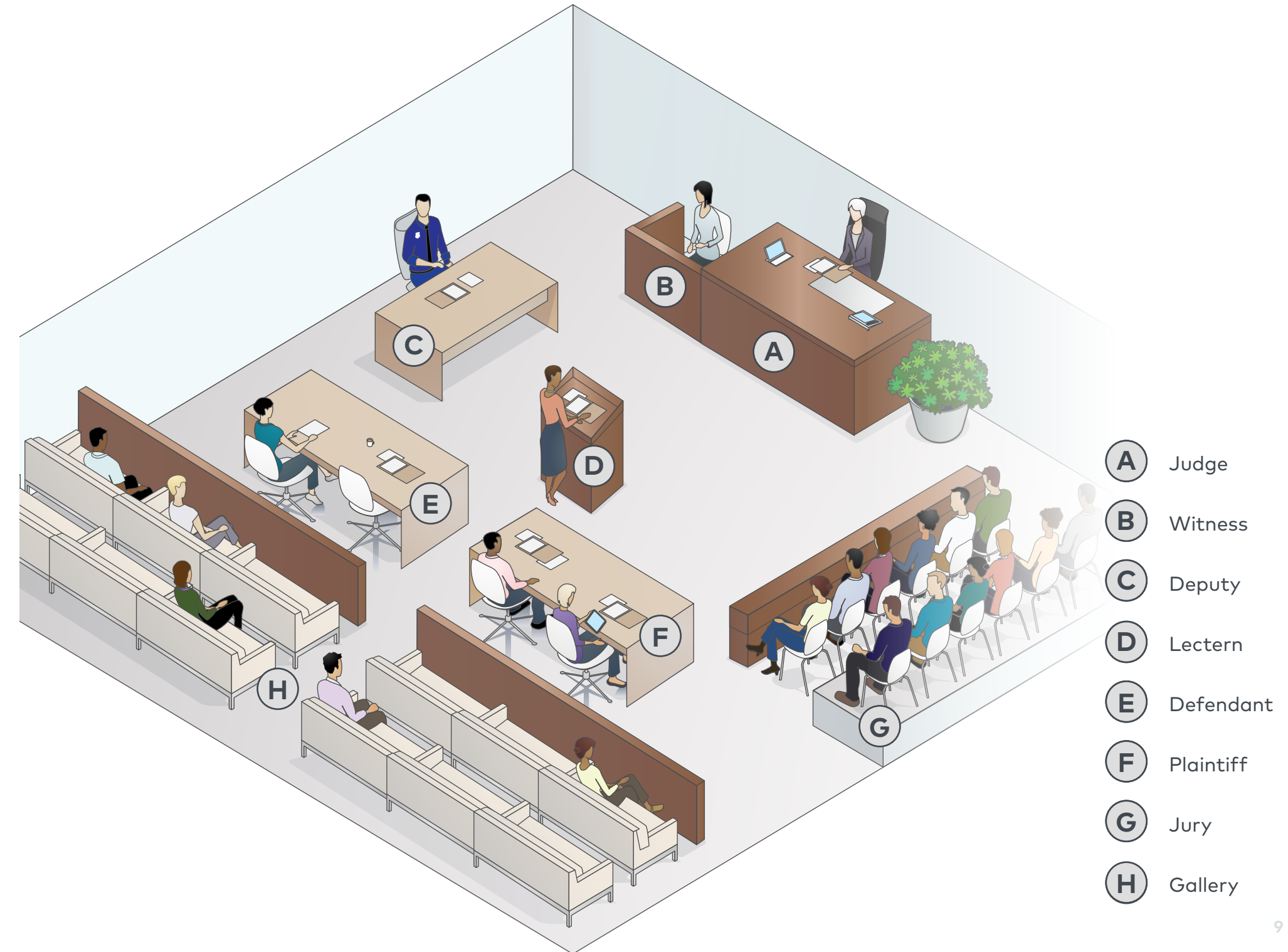

**DISTRICT COURTROOM**

DEFENDANT, JUDGE, & DEPUTY

Bill of Materials

| Qty | Model Number        | Description                                 |
|-----|---------------------|---|
| 3   | DM-NVX-360          | DM NVX® Network AV Encoder/Decoder Card     |
| 2   | DM-NVX-360C         | DM NVX® Network AV Encoder/Decoder Card     |
| 1   | DMF-CI-8            | DigitalMedia™ Card Chassis                  |
| 3   | FT2-500-MECH-PTL-B  | FlipTop™ FT2 Series Cable Management System |
| 3   | FT2A-CBL-PT-4K-HD   | Pass-Through Cable for FT2 Series           |
| 3   | FT2A-CBL-PT-CAT6    | Pass-Through Cable for FT2 Series           |
| 3   | FT2A-PWR-US-1-BASIC | AC Power Outlet Module for FT2 Series       |
| 3   | TS-1070-B-S         | 10.1 in. Tabletop Touch Screen              |

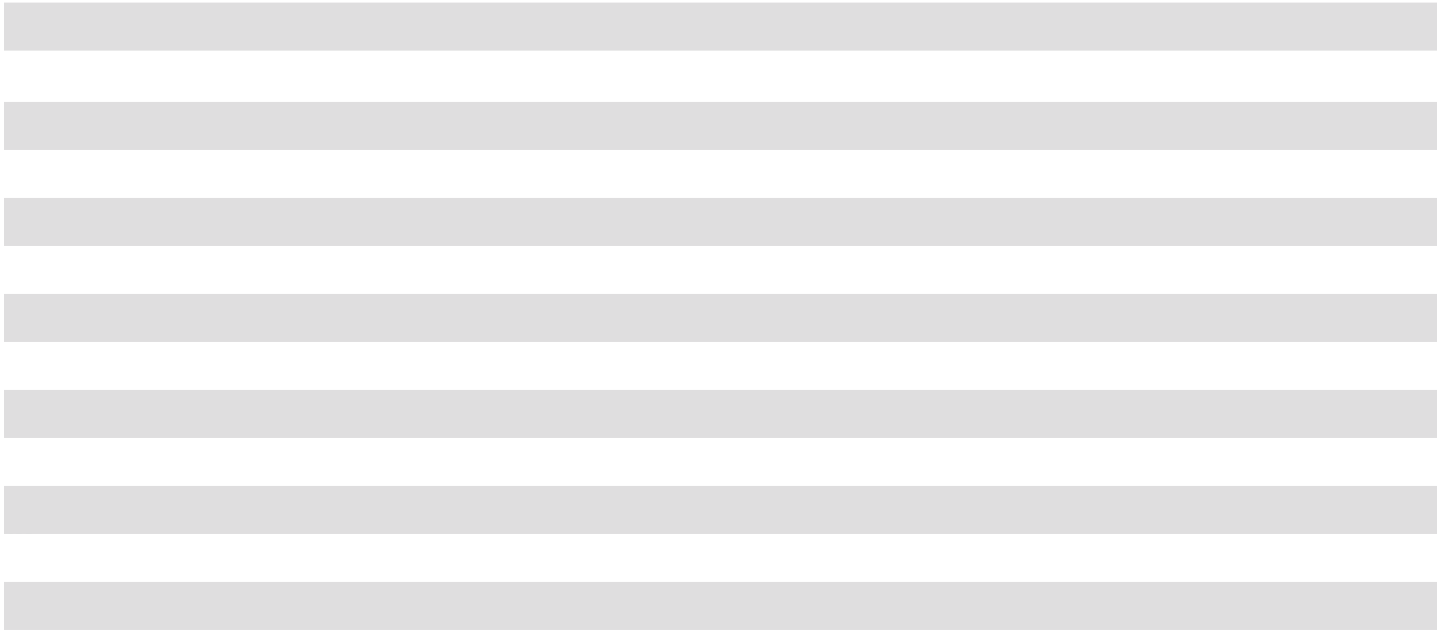

Defendant

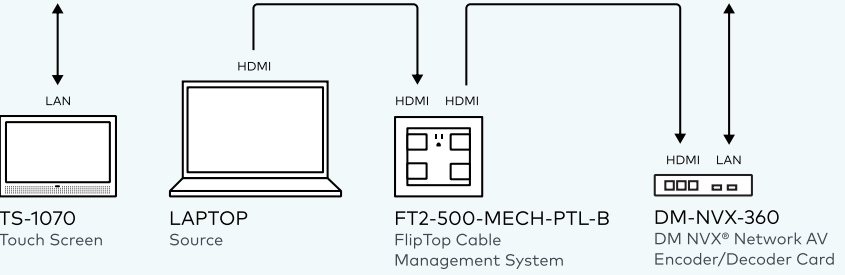

Judge & Deputy

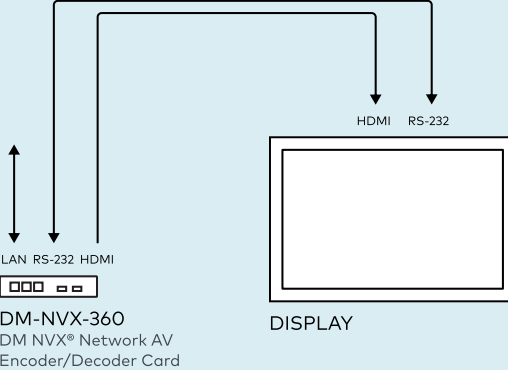
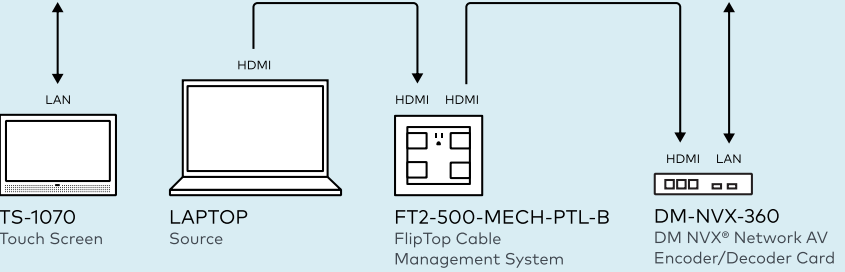



**DISTRICT COURTROOM**

FRONT OF ROOM & PLAINTIFF

Bill of Materials

| Qty | Model Number        | Description                                 |
|-----|---------------------|---|
| 2   | DM-NVX-360          | DM NVX® Network AV Encoder/Decoder Card     |
| 1   | FT2-500-MECH-PTL-B  | FlipTop™ FT2 Series Cable Management System |
| 1   | FT2A-CBL-PT-4K-HD   | Pass-Through Cable for FT2 Series           |
| 1   | FT2A-CBL-PT-CAT6    | Pass-Through Cable for FT2 Series           |
| 1   | FT2A-PWR-US-1-BASIC | AC Power Outlet Module for FT2 Series       |
| 1   | TS-1070-B-S         | 10.1 in. Tabletop Touch Screen              |

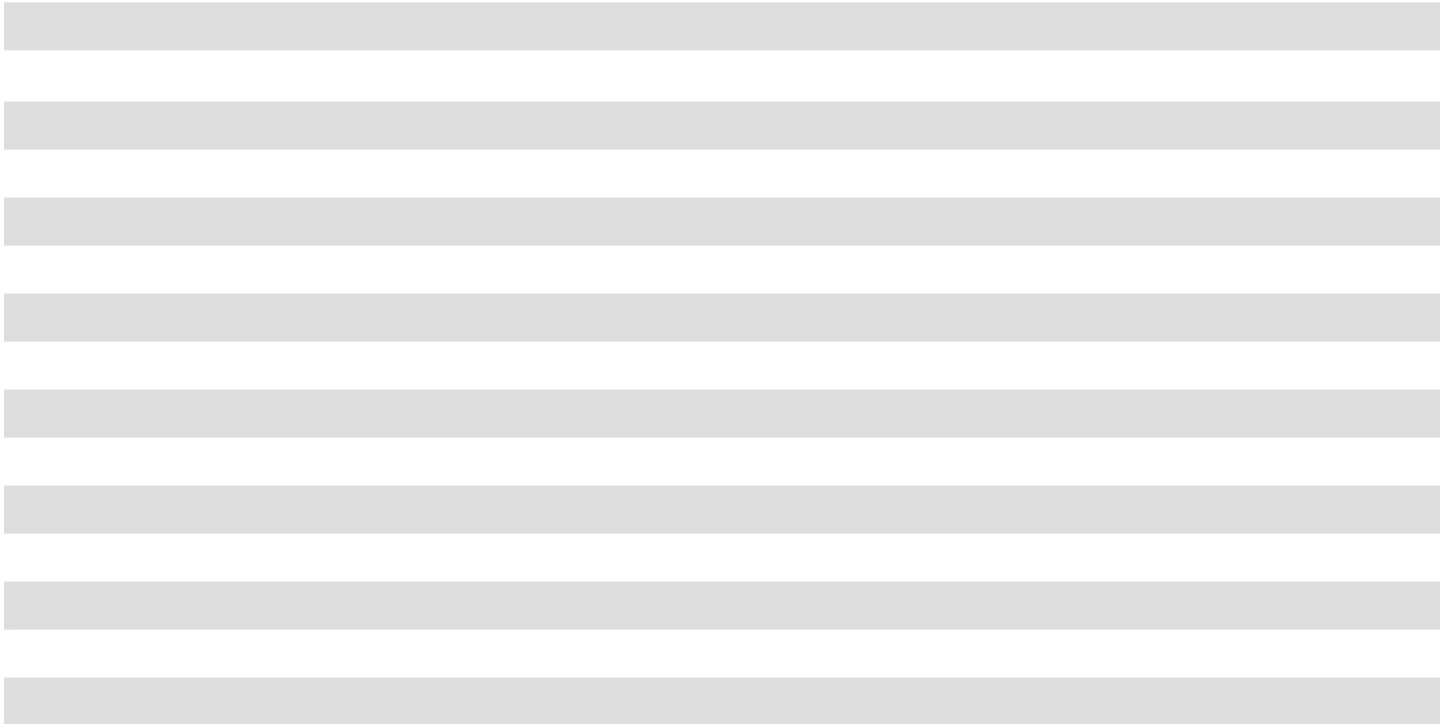

Front of Room

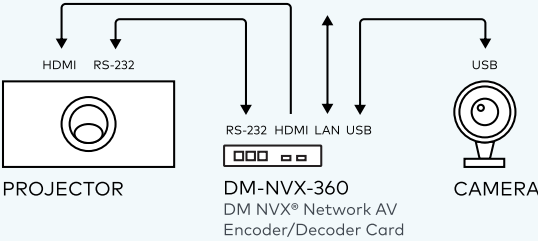

Plaintiff

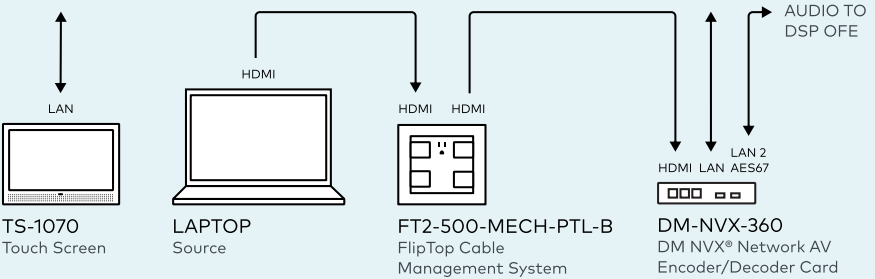











DISTRICT COURTROOM

WITNESS

Bill of Materials

| Qty | Model Number        | Description                                 |
|-----|---------------------|---|
| 1   | DM-DGE-200-C        | Digital Graphics Engine 200                 |
| 2   | DM-NVX-360          | DM NVX® Network AV Encoder/Decoder          |
| 1   | FT2-500-MECH-PTL-B  | FlipTop™ FT2 Series Cable Management System |
| 1   | FT2A-CBL-PT-4K-HD   | Pass-Through Cable for FT2 Series           |
| 1   | FT2A-CBL-PT-CAT6    | Pass-Through Cable for FT2 Series           |
| 1   | FT2A-PWR-US-1-BASIC | AC Power Outlet Module for FT2 Series       |
| 1   | TSD-2220-B          | 21.5" HD Touch Screen                       |

Witness

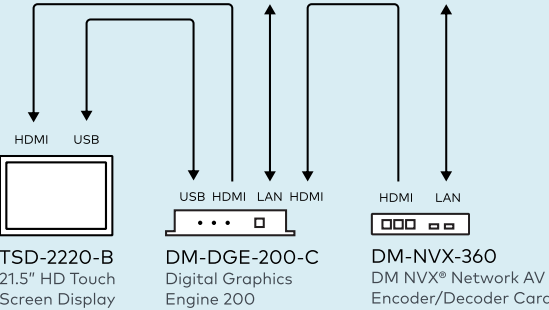
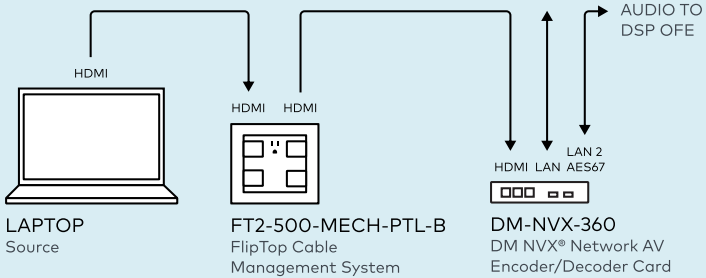

# DISTRICT COURTROOM

## LECTERN Bill of Materials

| Qty | Model Number        | Description                                 |
|-----|---------------------|---|
| 1   | DM-DGE-200-C        | Digital Graphics Engine 200                 |
| 3   | DM-NVX-360          | DM NVX® Network AV Encoder/Decoder          |
| 1   | FT2-500-MECH-PTL-B  | FlipTop™ FT2 Series Cable Management System |
| 1   | FT2A-CBL-PT-4K-HD   | Pass-Through Cable for FT2 Series           |
| 1   | FT2A-CBL-PT-CAT6    | Pass-Through Cable for FT2 Series           |
| 1   | FT2A-PWR-US-1-BASIC | AC Power Outlet Module for FT2 Series       |
| 1   | TS-1070-B-S         | 10.1 in. Tabletop Touch Screen              |
| 1   | TSD-2220-B          | 21.5" HD Touch Screen                       |

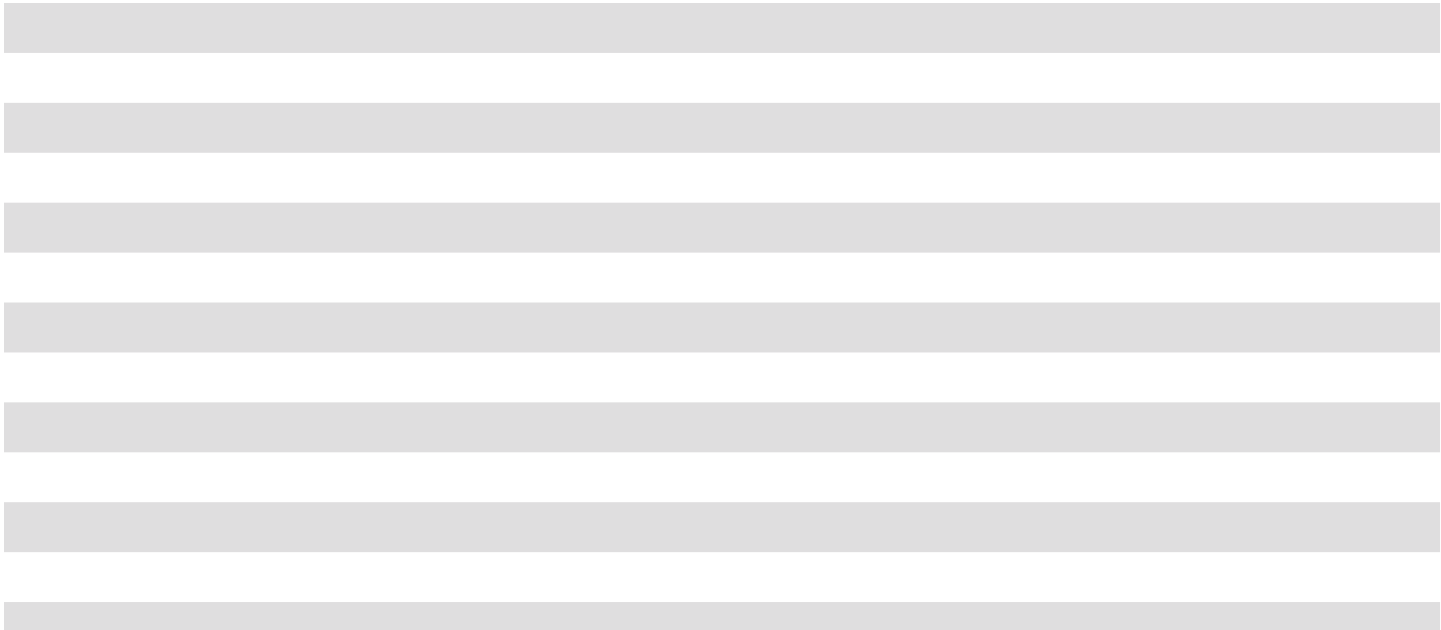

### Lectern

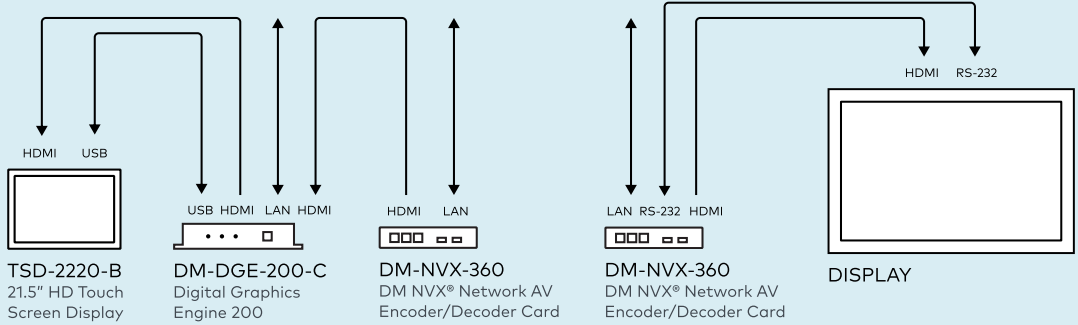
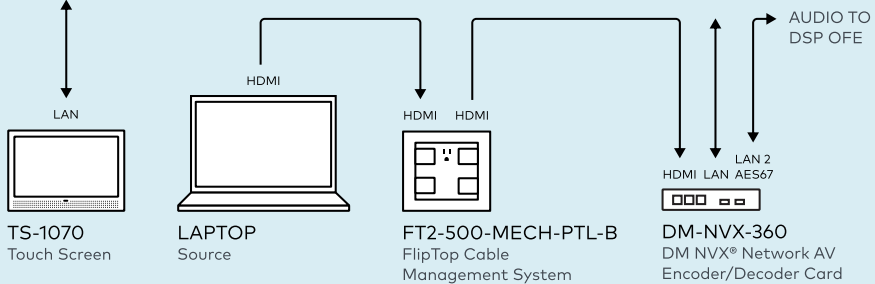



# DISTRICT COURTROOM

## RACK & CEILING

### Bill of Materials

| Qty | Model Number        | Description   |
|-----|---------------------|---|
| 1   | AM-3200             | AirMedia® Presentation System 3200  |
| 1   | AMP-8075            | 8-Channel Power Amplifier   |
| 1   | CP4N                | 4-Series™ Control System  |
| 1   | DGE-100             | Digital Graphics Engine 100   |
| 5   | DM-NVX-360          | DM NVX® Network AV Encoder/Decoder  |
| 5   | DM-NVX-360C         | DM NVX® Network AV Encoder/Decoder Card                                       |
| 1   | DM-NVX-DIR-80       | DM NVX Director® Virtual Switching Appliance                                  |
| 1   | DMF-CI-8            | DigitalMedia™ Card Chassis  |
| 12  | SAROS IC8T-W-T-EACH | Saros® 8" 2-Way In-Ceiling Speaker  |
| 1   | UC-C100-T           | Crestron Flex Video Conference System Integrator Kit for Microsoft Team Rooms |
| 1   | UC-FLEXCARE-C       | Premium Crestron Flex Support   |

Rack

Ceiling

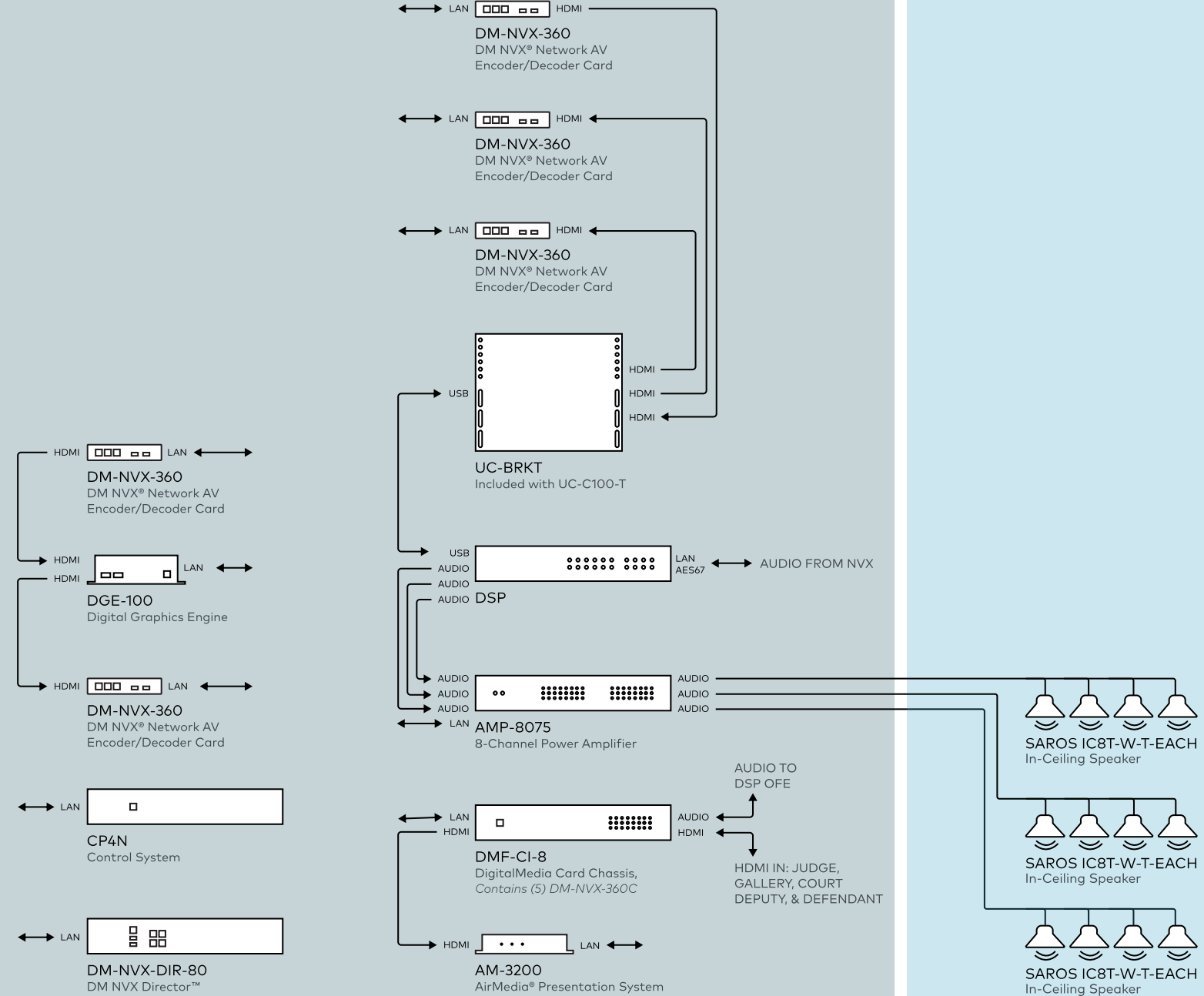

## COUNTY COURTROOM

### TOTAL SOLUTION

#### Bill of Materials

| Qty | Model Number        | Description   |
|-----|---------------------|---|
| 1   | AMP-X300            | X-Series Amplifier  |
| 3   | DM-NVX-360          | DM NVX Network AV Encoder/Decoder   |
| 3   | DM-NVX-363          | DM NVX Network AV Encoder/Decoder with Downmixing and Dante® Audio              |
| 10  | DM-NVX-D30          | DM NVX Network AV Decoder   |
| 5   | DM-NVX-E30          | DM NVX Network AV Encoder   |
| 7   | FT2-500-MECH-PTL-B  | FlipTop™ FT2 Series Cable Management System                                     |
| 7   | FT2A-CBL-PT-4K-HD   | Pass-Through Cable for FT2 Series   |
| 7   | FT2A-CBL-PT-CAT6    | Pass-Through Cable for FT2 Series   |
| 2   | FT2A-PLT-BLANK-10   | FlipTop™ FT2 Series Cable Management System Blank Plate                         |
| 2   | FT2A-PLT-PT-10      | FlipTop™ FT2 Series Cable Management System Cable Pass-Through Plate            |
| 7   | FT2A-PWR-US-1-BASIC | AC Power Outlet Module for FT2 Series   |
| 1   | RMC4                | 4-Series Control System   |
| 6   | SAROS IC8T-W-T-EACH | Saros 8" 2-Way In-Ceiling Speaker   |
| 2   | TS-1070-B-S         | 10.1 in. Tabletop Touch Screen  |
| 1   | UC-C100-T           | Crestron Flex Video Conference System Integrator Kit for Microsoft Teams® Rooms |
| 1   | UC-FLEXCARE-C       | Premium Crestron Flex Support   |

Courtroom featuring evidence presentation and videoconferencing.

#### System Features

FlipTop touch screen control at attorney tables and lectern

Low cost switching design using DM NVX® AV-over-IP technology

Multiple display support

Remote video conferencing capability

Touch screen control at judge and deputy/clerk locations

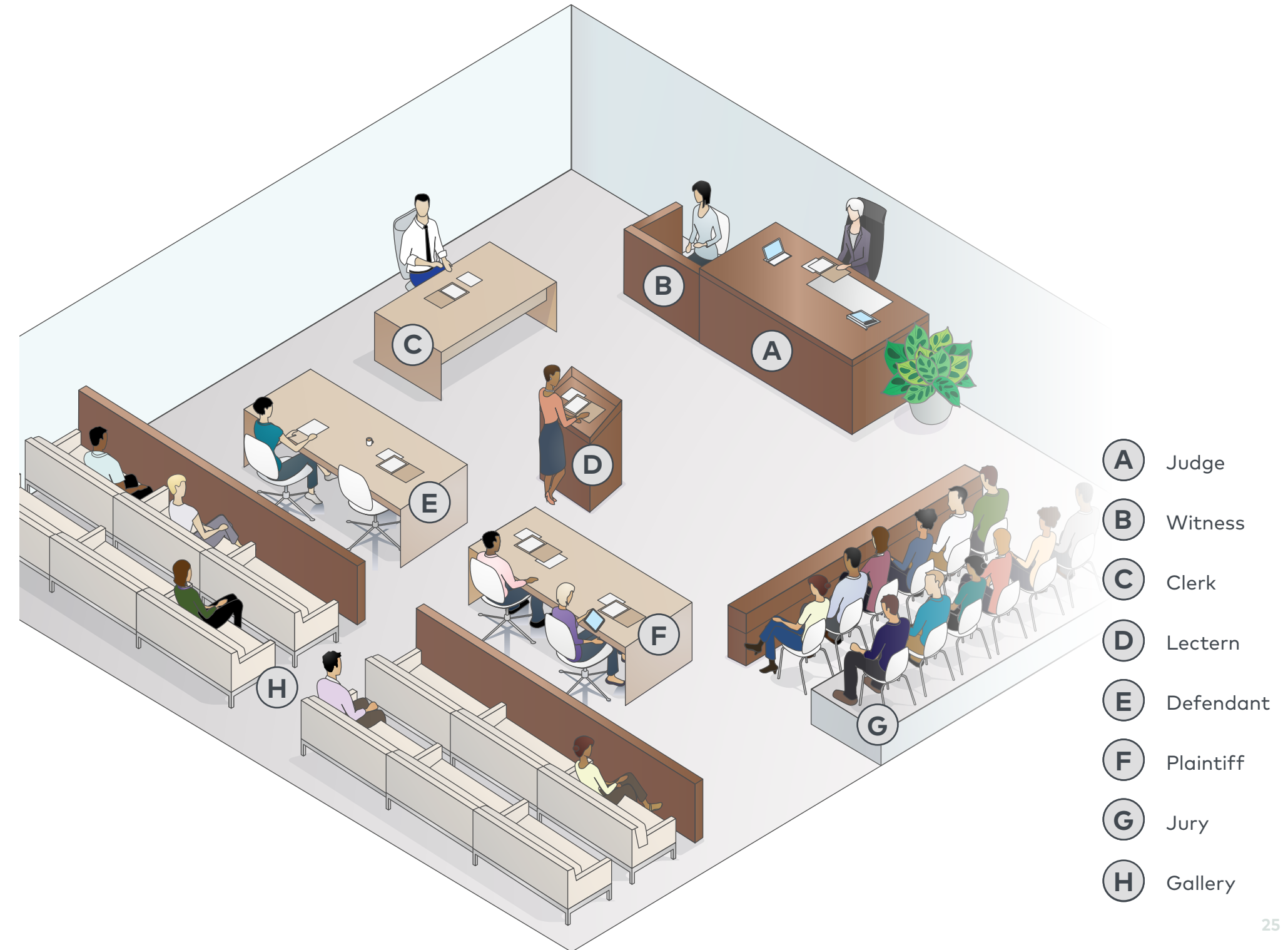

- A** Judge
- B** Witness
- C** Clerk
- D** Lectern
- E** Defendant
- F** Plaintiff
- G** Jury
- H** Gallery



COUNTY COURTROOM

JUDGE & CLERK

Bill of Materials

| Qty | Model Number        | Description  |
|-----|---------------------|--|
| 1   | DM-NVX-360          | DM NVX Network AV Encoder/Decoder                                  |
| 2   | DM-NVX-363          | DM NVX Network AV Encoder/Decoder with Downmixing and Dante® Audio |
| 1   | DM-NVX-D30          | DM NVX Network AV Decoder  |
| 2   | FT2-500-MECH-PTL-B  | FlipTop™ FT2 Series Cable Management System                        |
| 2   | FT2A-CBL-PT-4K-HD   | Pass-Through Cable for FT2 Series                                  |
| 2   | FT2A-CBL-PT-CAT6    | Pass-Through Cable for FT2 Series                                  |
| 2   | FT2A-PWR-US-1-BASIC | AC Power Outlet Module for FT2 Series                              |
| 2   | TS-1070-B-S         | 10.1 in. Tabletop Touch Screen                                     |

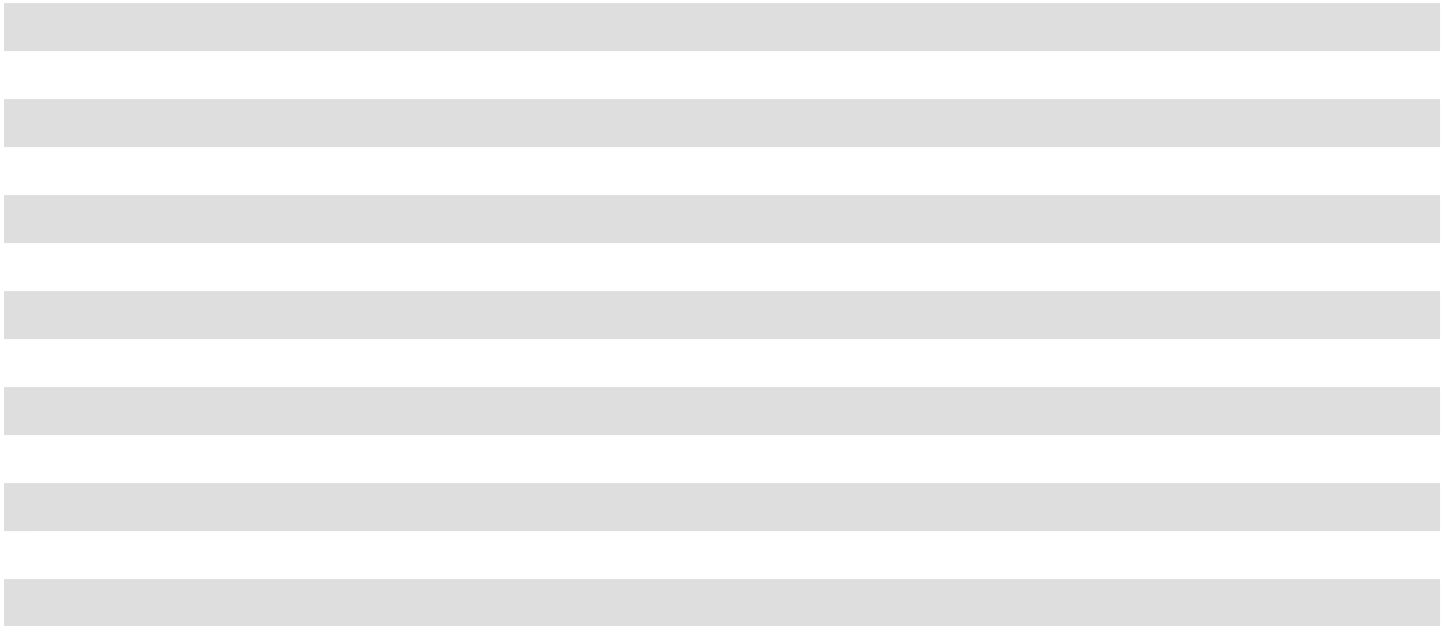

Judge

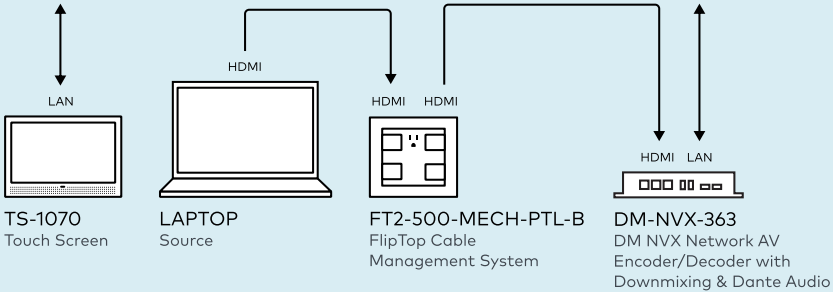

Clerk

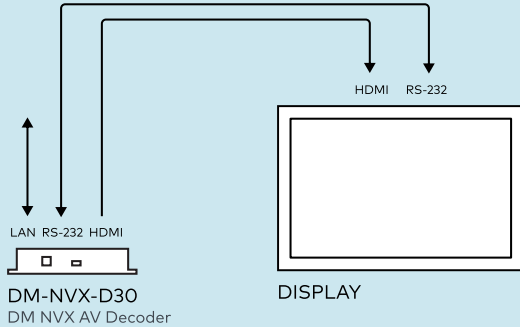
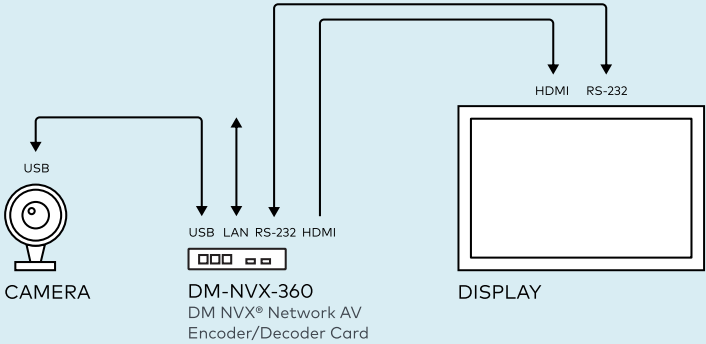
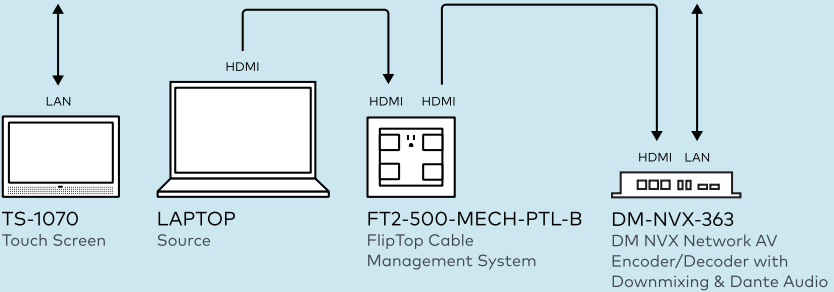

LECTERN

Bill of Materials

| Qty | Model Number        | Description                                 |
|-----|---------------------|---|
| 1   | DM-NVX-D30          | DM NVX Network AV Decoder                   |
| 1   | DM-NVX-E30          | DM NVX Network AV Encoder                   |
| 1   | FT2-500-MECH-PTL-B  | FlipTop™ FT2 Series Cable Management System |
| 1   | FT2A-CBL-PT-4K-HD   | Pass-Through Cable for FT2 Series           |
| 1   | FT2A-CBL-PT-CAT6    | Pass-Through Cable for FT2 Series           |
| 1   | FT2A-PWR-US-1-BASIC | AC Power Outlet Module for FT2 Series       |
| 1   | TS-1070-B-S         | 10.1 in. Tabletop Touch Screen              |

Lectern

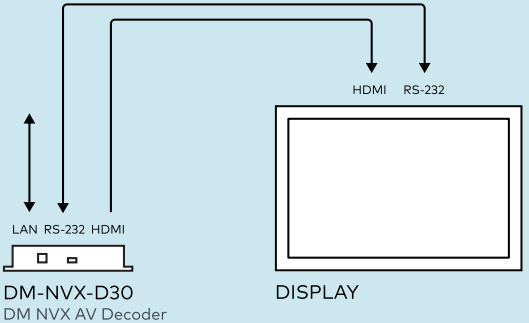
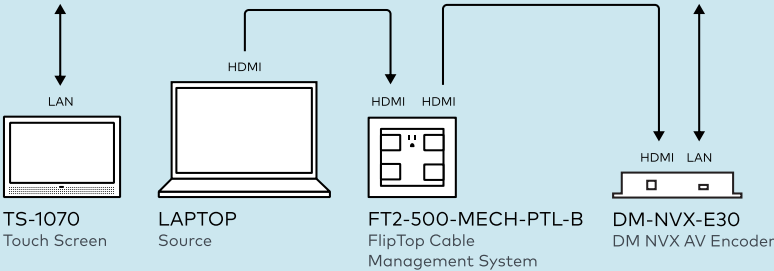



COUNTY COURTROOM

PLAINTIFF, WITNESS, DEFENDANT,  
SPARE & JURY

Bill of Materials

| Qty | Model Number        | Description                                 |
|-----|---------------------|---|
| 7   | DM-NVX-D30          | DM NVX Network AV Decoder                   |
| 4   | DM-NVX-E30          | DM NVX Network AV Encoder                   |
| 4   | FT2-500-MECH-PTL-B  | FlipTop™ FT2 Series Cable Management System |
| 4   | FT2A-CBL-PT-4K-HD   | Pass-Through Cable for FT2 Series           |
| 4   | FT2A-CBL-PT-CAT6    | Pass-Through Cable for FT2 Series           |
| 4   | FT2A-PWR-US-1-BASIC | AC Power Outlet Module for FT2 Series       |

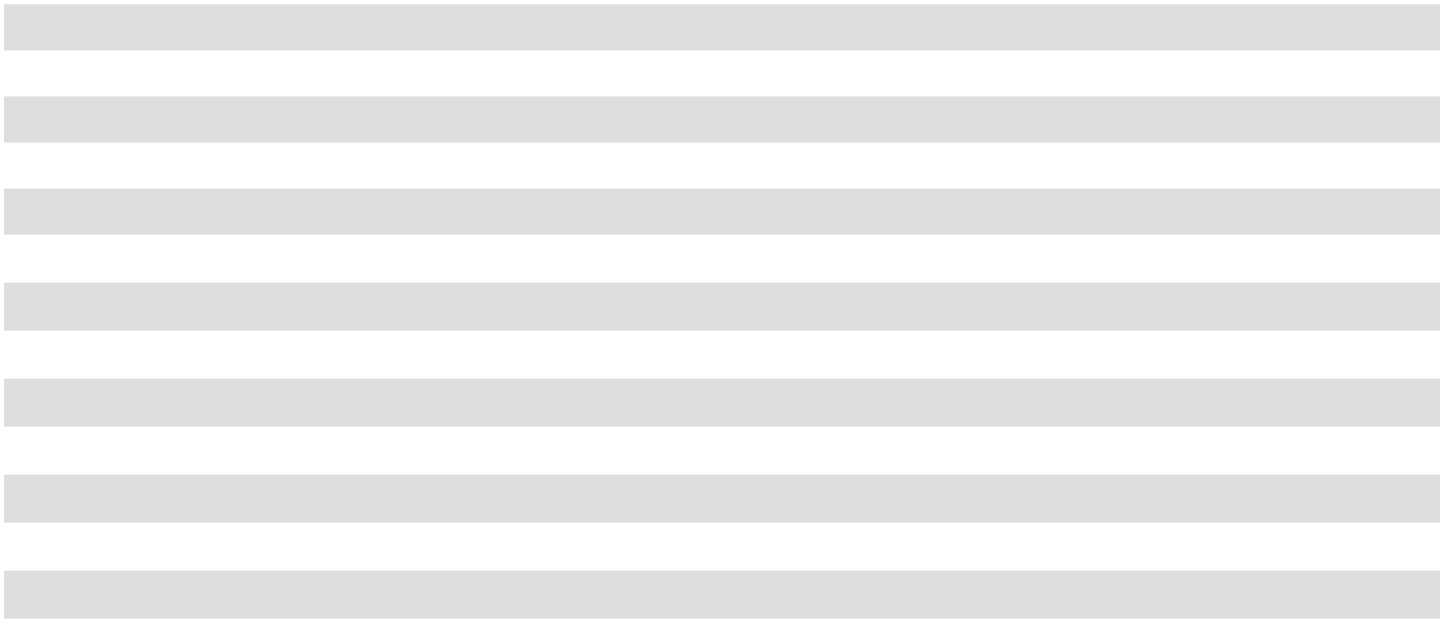

Plaintiff,  
Witness &  
Defendant

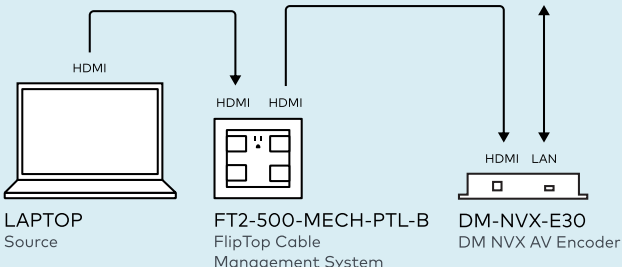

Spare

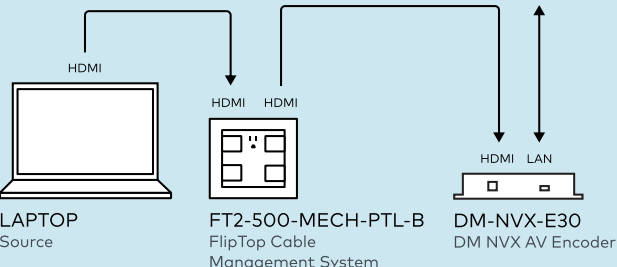

Jury

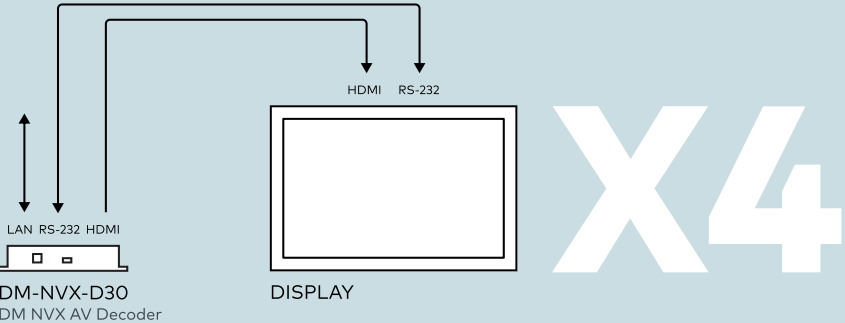
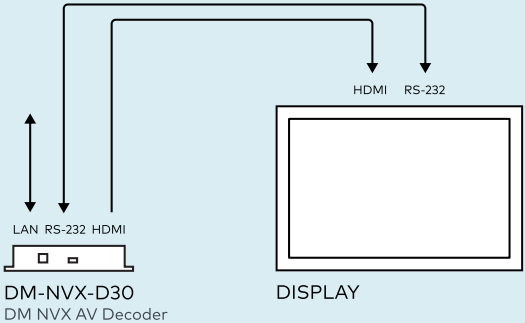

# COUNTY COURTROOM

## RACK & CEILING

### Bill of Materials

| Qty | Model Number        | Description   |
|-----|---------------------|---|
| 1   | AMP-X300            | X-Series Amplifier  |
| 2   | DM-NVX-360          | DM NVX Network AV Encoder/Decoder   |
| 1   | DM-NVX-363          | DM NVX Network AV Encoder/Decoder with Downmixing and Dante® Audio            |
| 1   | DM-NVX-D30          | DM NVX Network AV Decoder   |
| 1   | RMC4                | 4-Series Control System   |
| 6   | SAROS IC8T-W-T-EACH | Saros 8" 2-Way In-Ceiling Speaker   |
| 1   | UC-C100-T           | Crestron Flex Video Conference System Integrator Kit for Microsoft Team Rooms |
| 1   | UC-FLEXCARE-C       | Premium Crestron Flex Support   |

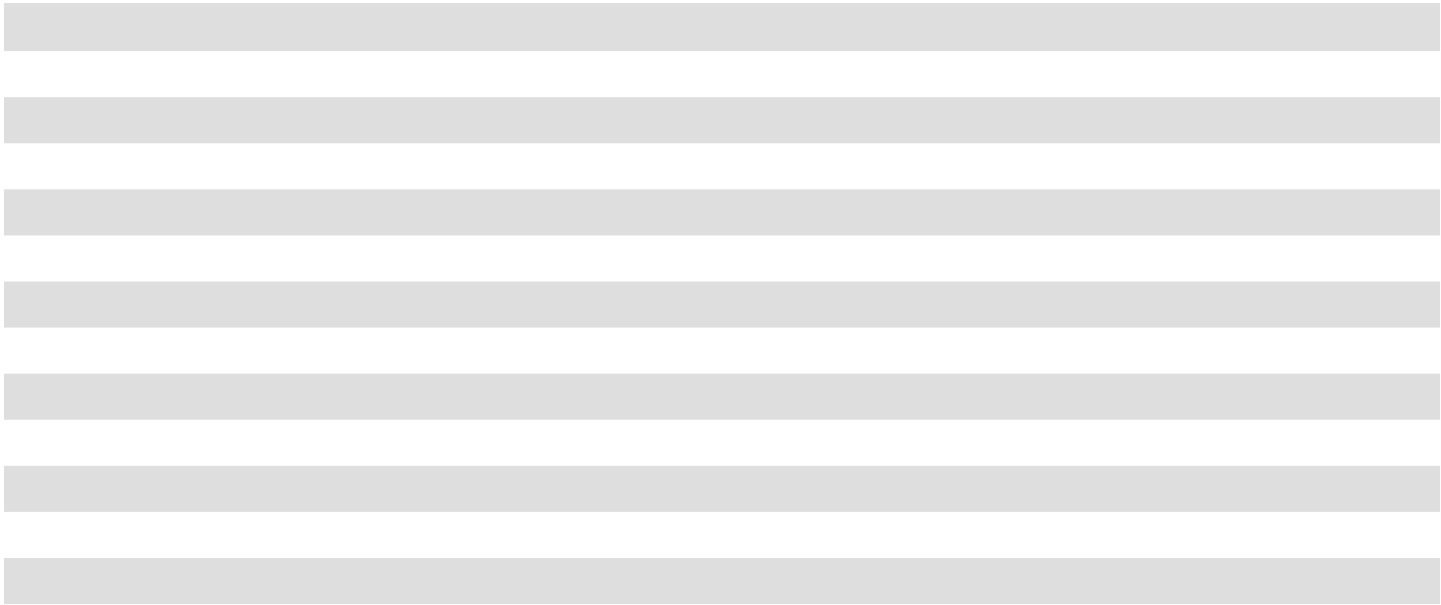

Rack

Ceiling

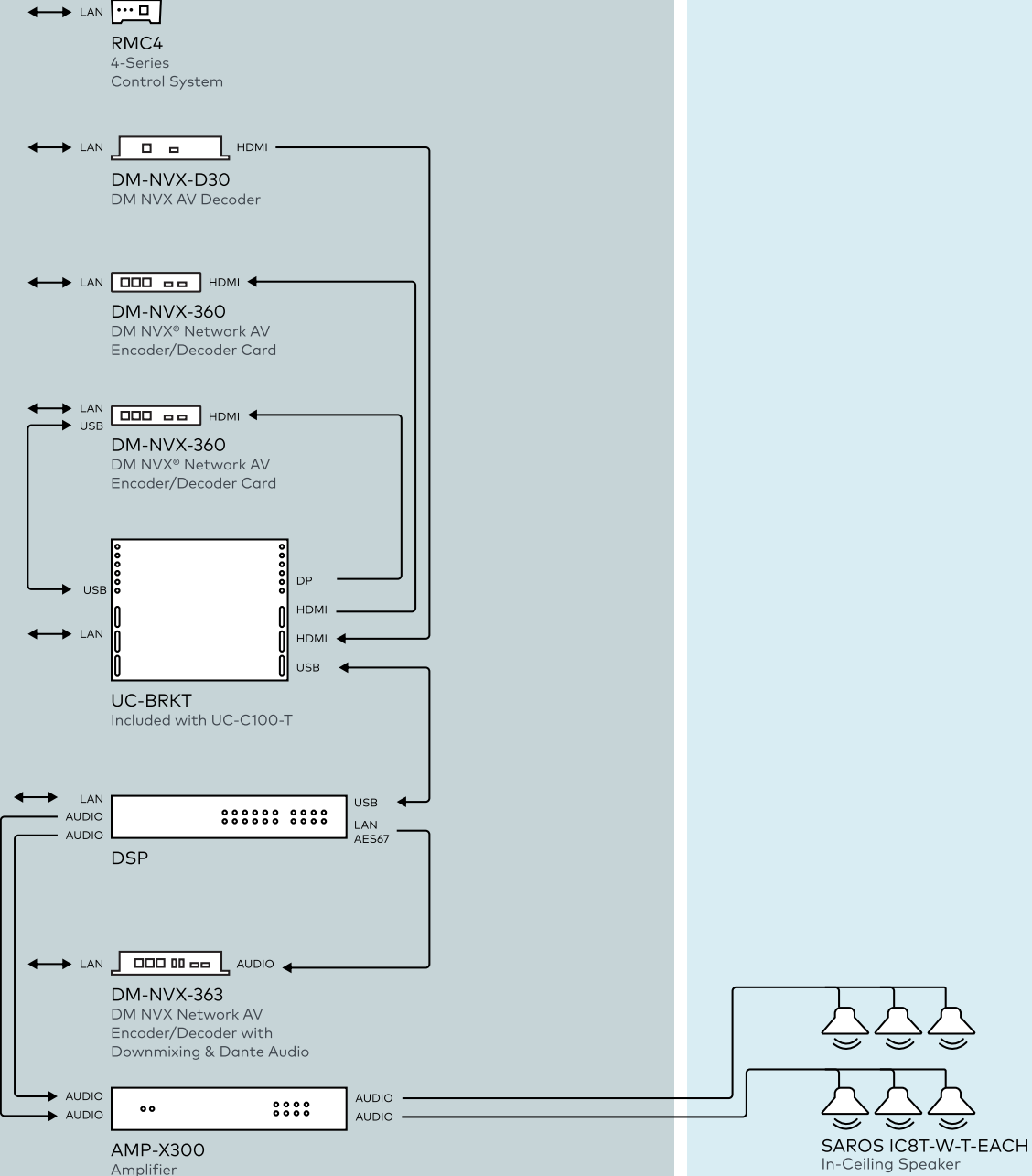



## CIVIL COURTROOM

### TOTAL SOLUTION

#### Bill of Materials

| Qty | Model Number           | Description   |
|-----|------------------------|---|
| 1   | AMP-X300               | X-Series Amplifier  |
| 1   | CP4N                   | 4-Series Control System   |
| 1   | DM-MD8X8-CPU3          | 8X8 DigitalMedia Switcher   |
| 1   | DM-PSU-16-PLUS         | 16-Port PoDM+ Power Supply  |
| 6   | DM-RMC-4KZ-SCALER-C    | DigitalMedia Receiver and Room Controller with Scaler                         |
| 3   | DM-TX-4KZ-302-C        | DigitalMedia Transmitter 302  |
| 3   | DMC-4KZ-C              | DigitalMedia Input Card for DM® Switchers                                     |
| 3   | DMC-4KZ-CO-HD          | 2-Channel DigitalMedia Output Card for DM Switchers                           |
| 3   | DMC-4KZ-HD             | 2-Channel DigitalMedia Output Card for DM Switchers                           |
| 1   | DMC-4KZ-HDO            | 2-Channel HDMI Scaling Output Card for DM Switchers                           |
| 3   | FT2-500-MECH-PTL-B     | FlipTop™ FT2 Series Cable Management System                                   |
| 3   | FT2A-CBL-PT-4K-HD      | Pass-Through Cable for FT2 Series   |
| 3   | FT2A-CBL-PT-4K-USBC-HD | Pass-Through Cable for FT2 Series   |
| 3   | FT2A-CBL-PT-CAT6       | Pass-Through Cable for FT2 Series   |
| 1   | FT2A-PLT-BLANK-10      | FlipTop™ FT2 Series Cable Management System Blank Plate                       |
| 1   | FT2A-PLT-PT-10         | FlipTop™ FT2 Series Cable Management System Cable Pass-Through Plate          |
| 3   | FT2A-PWR-US-1-BASIC    | AC Power Outlet Module for FT2 Series   |
| 1   | HD-WP-4K-401-C         | 4K Multi-Window Video Processor   |
| 10  | SAROS IC8T-W-T-EACH    | Saros 8" 2-Way In-Ceiling Speaker   |
| 2   | TS-1070-B-S            | 10.1 in. Tabletop Touch Screen  |
| 1   | UC-C100-T              | Crestron Flex Video Conference System Integrator Kit for Microsoft Team Rooms |
| 1   | UC-FLEXCARE-C          | Premium Crestron Flex Support   |
| 1   | USB-EXT-2 KIT          | USB over Category Cable Extender, Local and Remote                            |

Courtroom featuring evidence presentation and videoconferencing.

#### System Features

FlipTop™ touch screen control at attorney tables and lectern

HDBaseT® switcher with configurable card chassis

Multiple display support

Remote video conferencing capability

Touch screen control at judge, deputy, and lectern

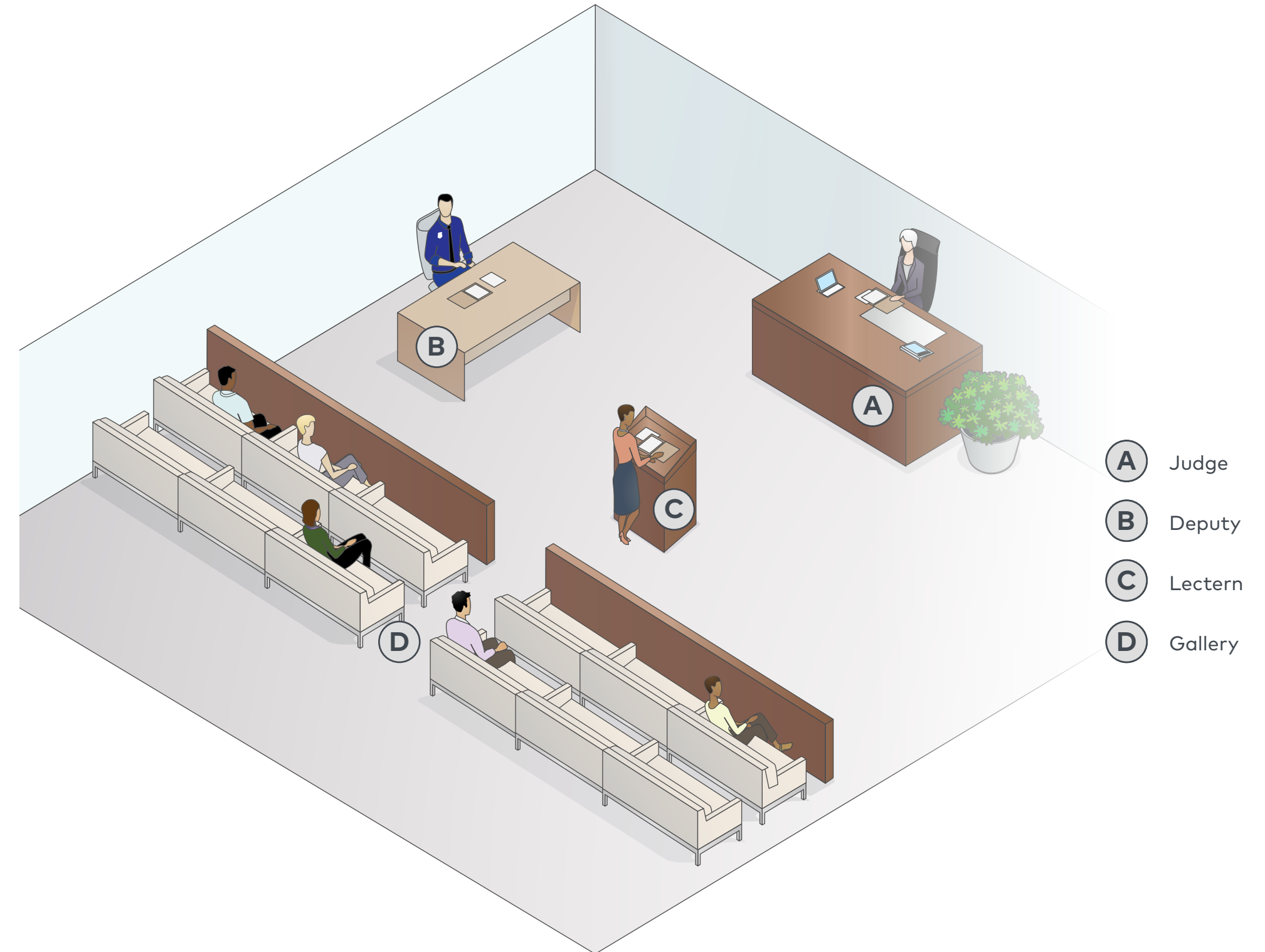

- A** Judge
- B** Deputy
- C** Lectern
- D** Gallery

CIVIL COURTROOM

JUDGE & DEPUTY

Bill of Materials

| Qty | Model Number           | Description   |
|-----|------------------------|---|
| 1   | DM-MD8X8-CPU3          | 8x8 DigitalMedia™ Switcher                            |
| 1   | DM-PSU-16-PLUS         | 16-Port PoDM+ Power Supply                            |
| 2   | DM-RMC-4KZ-SCALER-C    | DigitalMedia Receiver and Room Controller with Scaler |
| 2   | DM-TX-4KZ-302-C        | DigitalMedia Transmitter 302                          |
| 3   | DMC-4KZ-C              | DigitalMedia Input Card for DM® Switchers             |
| 3   | DMC-4KZ-CO-HD          | DMC-4KZ-CO-HD   |
| 3   | DMC-4KZ-HD             | 2-Channel DigitalMedia Output Card for DM Switchers   |
| 1   | DMC-4KZ-HDO            | 2-Channel HDMI® Scaling Output Card for DM Switchers  |
| 2   | FT2-500-MECH-PTL-B     | FlipTop™ FT2 Series Cable Management System           |
| 2   | FT2A-CBL-PT-4K-HD      | Pass-Through Cable for FT2 Series                     |
| 2   | FT2A-CBL-PT-4K-USBC-HD | Pass-Through Cable for FT2 Series                     |
| 2   | FT2A-CBL-PT-CAT6       | Pass-Through Cable for FT2 Series                     |
| 2   | FT2A-PWR-US-1-BASIC    | AC Power Outlet Module for FT2 Series                 |
| 1   | HD-WP-4K-401-C         | 4K Multi-Window Video Processor                       |
| 2   | TS-1070-W-S            | 10.1 in. Tabletop Touch Screen                        |

Judge & Deputy

Rack

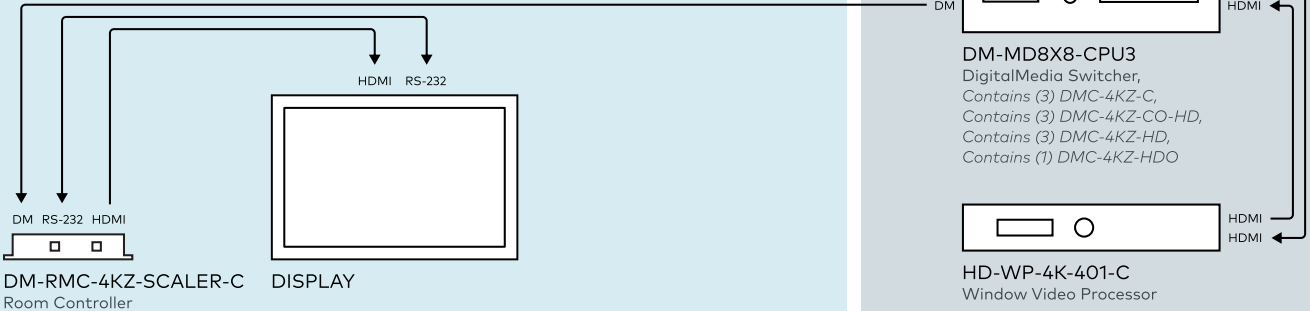
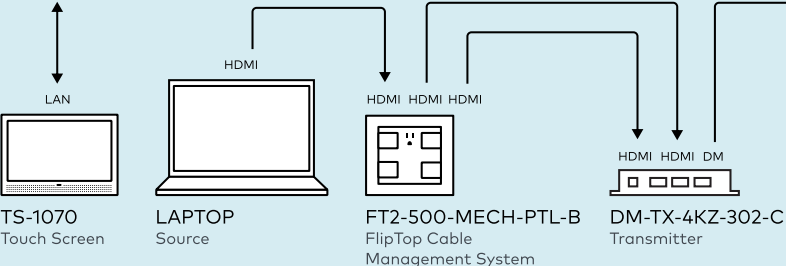



# LECTERN

## Bill of Materials

| Qty | Model Number           | Description   |
|-----|------------------------|---|
| 1   | DM-MD8X8-CPU3          | 8X8 DigitalMedia Switcher                             |
| 1   | DM-PSU-16-PLUS         | 16-Port PoDM+ Power Supply                            |
| 1   | DM-RMC-4KZ-SCALER-C    | DigitalMedia Receiver and Room Controller with Scaler |
| 1   | DM-TX-4KZ-302-C        | DigitalMedia Transmitter 302                          |
| 3   | DMC-4KZ-C              | DigitalMedia Input Card for DM® Switchers             |
| 3   | DMC-4KZ-CO-HD          | 2-Channel DigitalMedia Output Card for DM Switchers   |
| 3   | DMC-4KZ-HD             | 2-Channel DigitalMedia Output Card for DM Switchers   |
| 1   | DMC-4KZ-HDO            | 2-Channel HDMI Scaling Output Card for DM Switchers   |
| 1   | FT2-500-MECH-PTL-B     | FlipTop™ FT2 Series Cable Management System           |
| 1   | FT2A-CBL-PT-4K-HD      | Pass-Through Cable for FT2 Series                     |
| 1   | FT2A-CBL-PT-4K-USBC-HD | Pass-Through Cable for FT2 Series                     |
| 1   | FT2A-CBL-PT-CAT6       | Pass-Through Cable for FT2 Series                     |
| 1   | FT2A-PWR-US-1-BASIC    | AC Power Outlet Module for FT2 Series                 |
| 1   | TS-1070-W-S            | 10.1 in. Tabletop Touch Screen                        |
| 1   | USB-EXT-2 KIT          | USB over Category Cable Extender, Local and Remote    |

Lectern

Rack

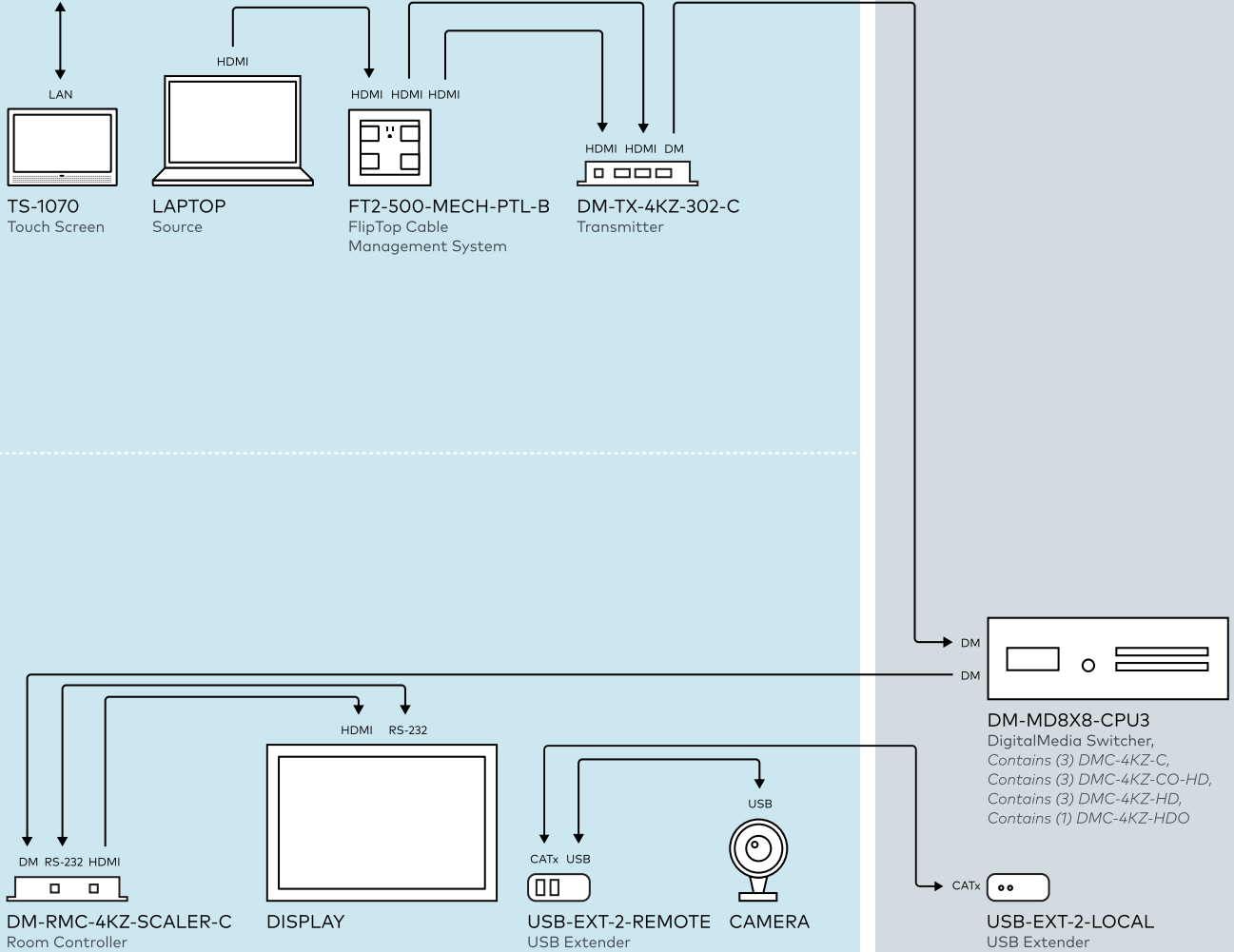

GALLERY

Bill of Materials

| Qty | Model Number        | Description   |
|-----|---------------------|---|
| 1   | DM-MD8X8-CPU3       | 8X8 DigitalMedia Switcher                             |
| 1   | DM-PSU-16-PLUS      | 16-Port PoDM+ Power Supply                            |
| 3   | DM-RMC-4KZ-SCALER-C | DigitalMedia Receiver and Room Controller with Scaler |
| 3   | DMC-4KZ-C           | DigitalMedia Input Card for DM® Switchers             |
| 3   | DMC-4KZ-CO-HD       | 2-Channel DigitalMedia Output Card for DM Switchers   |
| 3   | DMC-4KZ-HD          | 2-Channel DigitalMedia Output Card for DM Switchers   |
| 1   | DMC-4KZ-HDO         | 2-Channel HDMI Scaling Output Card for DM Switchers   |

Gallery

Rack

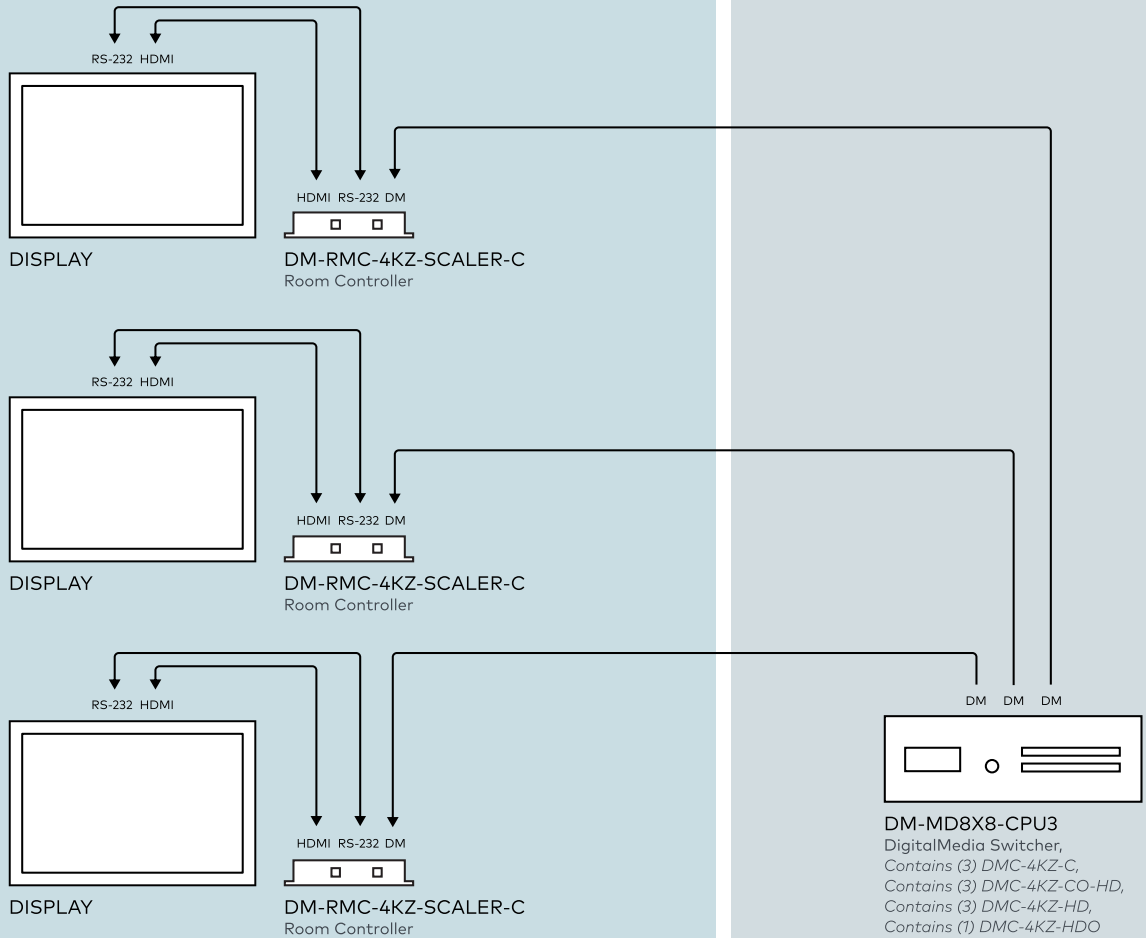

# RACK & CEILING

## Bill of Materials

| Qty | Model Number        | Description   |
|-----|---------------------|---|
| 1   | AMP-X300            | X-Series Amplifier  |
| 1   | CP4N                | 4-Series Control System   |
| 1   | DM-MD8X8-CPU3       | 8X8 DigitalMedia Switcher   |
| 1   | DM-PSU-16-PLUS      | 16-Port PoDM+ Power Supply  |
| 3   | DMC-4KZ-C           | DigitalMedia Input Card for DM® Switchers                                     |
| 3   | DMC-4KZ-CO-HD       | 2-Channel DigitalMedia Output Card for DM Switchers                           |
| 3   | DMC-4KZ-HD          | 2-Channel DigitalMedia Output Card for DM Switchers                           |
| 1   | DMC-4KZ-HDO         | 2-Channel HDMI Scaling Output Card for DM Switchers                           |
| 1   | HD-WP-4K-401-C      | 4K Multi-Window Video Processor   |
| 10  | SAROS IC8T-W-T-EACH | Saros 8" 2-Way In-Ceiling Speaker   |
| 1   | UC-C100-T           | Crestron Flex Video Conference System Integrator Kit for Microsoft Team Rooms |
| 1   | UC-FLEXCARE-C       | Premium Crestron Flex Support   |
| 1   | USB-EXT-2-LOCAL     | Included with USB-EXT-2 KIT   |

Rack

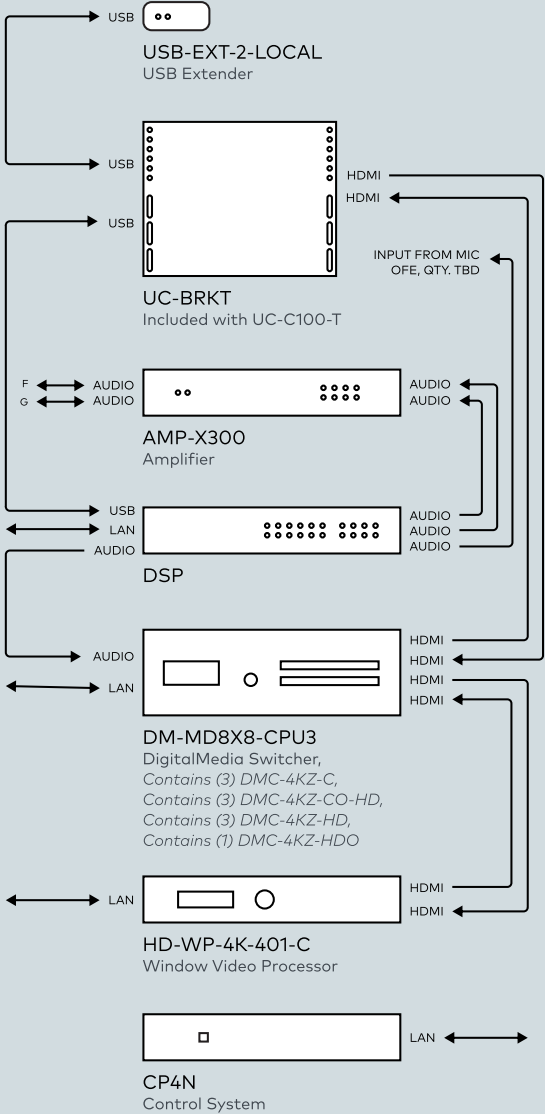

Ceiling

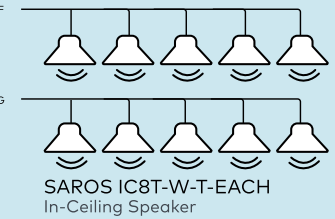



## SIMPLE COURTROOM

### TOTAL SOLUTION

#### Bill of Materials

| Qty | Model Number            | Description   |
|-----|-------------------------|---|
| 1   | CEN-ODT-C-POE           | Dual-Technology Occupancy Sensor, PoE   |
| 2   | DM-NVX-360              | DM NVX Network AV Encoder/Decoder   |
| 2   | DM-RMC-4KZ-SCALER-C     | DigitalMedia Receiver and Room Controller with Scaler                         |
| 2   | DM-TX-4KZ-100-C-1G-B-T  | DigitalMedia Wall Plate Transmitter   |
| 1   | DMPS3-4K-350-C-AIRMEDIA | 3-Series® 4K DigitalMedia Presentation System                                 |
| 3   | FT2-500-MECH-PTL-B      | FlipTop™ FT2 Series Cable Management System                                   |
| 3   | FT2A-CBL-PT-4K-HD       | Pass-Through Cable for FT2 Series   |
| 6   | FT2A-CBL-PT-CAT6        | Pass-Through Cable for FT2 Series   |
| 1   | FT2A-PLT-BLANK-10       | FlipTop™ FT2 Series Cable Management System Blank Plate Modules               |
| 1   | FT2A-PLT-PT-10          | FlipTop™ FT2 Series Cable Management System Cable Pass-Through Plate Modules, |
| 3   | FT2A-PWR-US-1-BASIC     | AC Power Outlet Module for FT2 Series   |
| 1   | HD-RX-101-C-E           | DM Lite® Receiver with HDMI over CATx   |
| 1   | HD-TX-101-C-E           | DM Lite Transmitter for HDMI Signal Extension                                 |
| 1   | PW-5430DUS              | High-Efficiency Power Pack  |
| 4   | SAROS IC8T-W-T-EACH     | Saros® 8" 2-Way In-Ceiling Speaker  |
| 1   | TS-1070-B-S             | 10.1 in. Tabletop Touch Screen  |
| 1   | TSS-1070-B-S-LB KIT     | 10.1" Room Scheduling Touch Screen  |

Low-cost small courtroom featuring evidence presentation.

#### System Features

FlipTop touch screen interfaces

All-in-one HDBaseT presentation switcher

Multiple display support

Touch screen control at judge, deputy/clerk, and lectern

Room scheduling

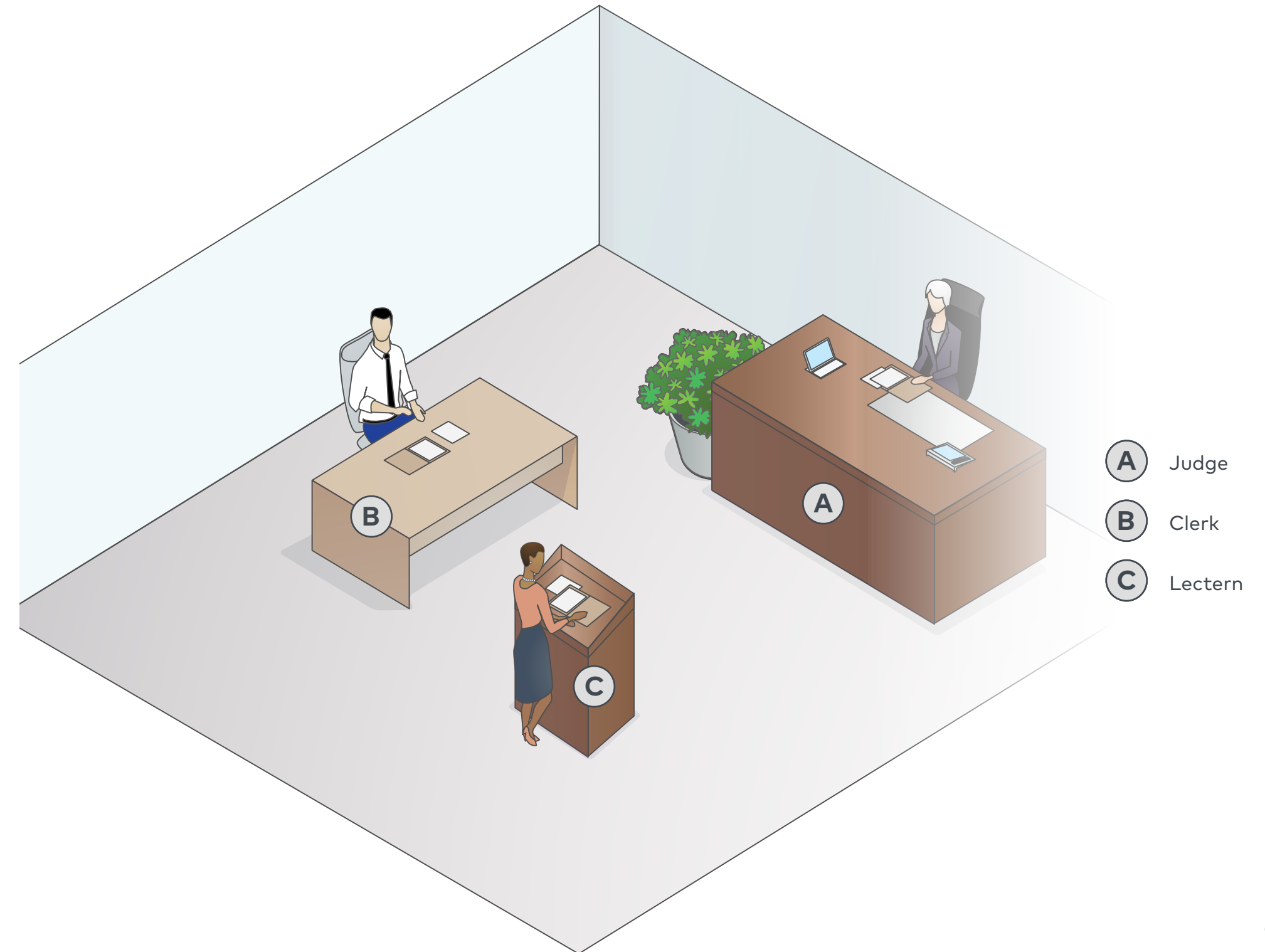

**SIMPLE COURTROOM**

OUTSIDE DOOR & JUDGE

Bill of Materials

| Qty | Model Number        | Description                                   |
|-----|---------------------|---|
| 1   | FT2-500-MECH-PTL-B  | FlipTop™ FT2 Series Cable Management System   |
| 1   | FT2A-CBL-PT-4K-HD   | Pass-Through Cable for FT2 Series             |
| 1   | FT2A-CBL-PT-CAT6    | Pass-Through Cable for FT2 Series             |
| 1   | FT2A-PWR-US-1-BASIC | AC Power Outlet Module for FT2 Series         |
| 2   | HD-TX-101-C-E       | DM Lite Transmitter for HDMI Signal Extension |
| 1   | TS-1070-B-S         | 10.1 in. Tabletop Touch Screen                |
| 1   | TSS-1070-B-S-LB KIT | 10.1" Room Scheduling Touch Screen            |

Outside Door

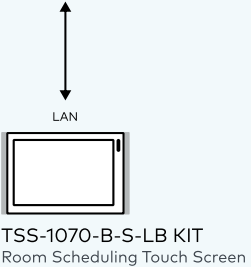

Rack

Judge

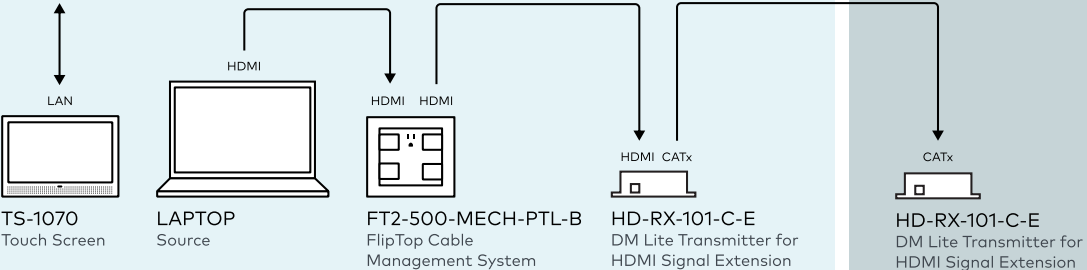

**SIMPLE COURTROOM**

CLERK, LECTERN, & FRONT WALL

Bill of Materials

| Qty | Model Number            | Description   |
|-----|-------------------------|---|
| 2   | DM-RMC-4KZ-SCALER-C     | DigitalMedia Receiver and Room Controller with Scaler |
| 2   | DM-TX-4KZ-100-C-1G-B-T  | DigitalMedia Wall Plate Transmitter                   |
| 1   | DMPS3-4K-350-C-AIRMEDIA | 3-Series® 4K DigitalMedia Presentation System         |
| 2   | FT2-500-MECH-PTL-B      | FlipTop™ FT2 Series Cable Management System           |
| 1   | FT2A-CBL-PT-4K-HD       | Pass-Through Cable for FT2 Series                     |
| 1   | FT2A-CBL-PT-CAT6        | Pass-Through Cable for FT2 Series                     |
| 1   | FT2A-PWR-US-1-BASIC     | AC Power Outlet Module for FT2 Series                 |

Clerk & Lectern

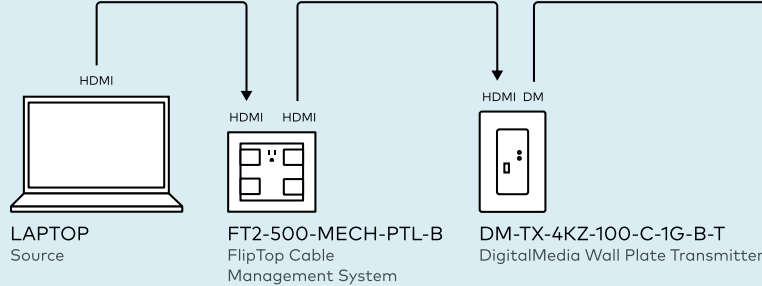

Rack

Front Wall

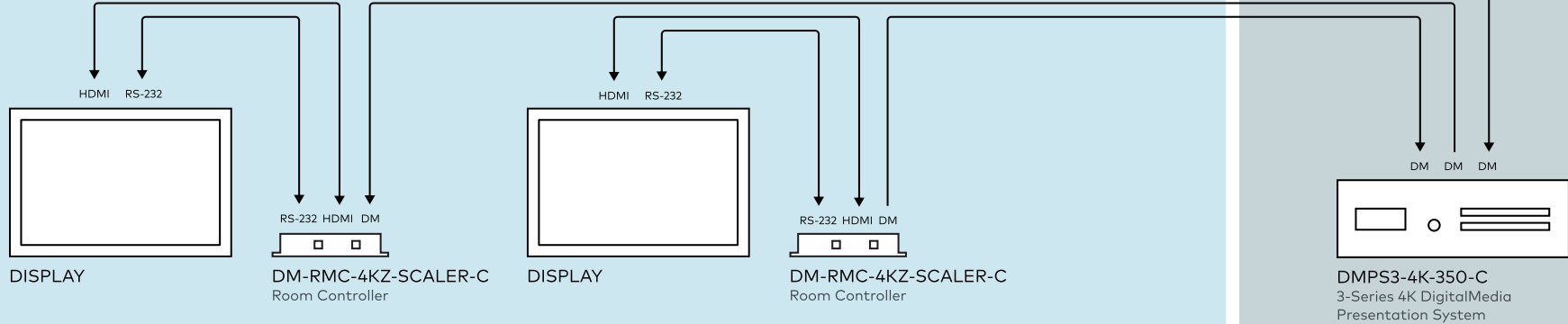



**SIMPLE COURTROOM**

RACK & CEILING

Bill of Materials

| Qty | Model Number            | Description                                   |
|-----|-------------------------|---|
| 1   | CEN-ODT-C-POE           | Dual-Technology Occupancy Sensor, PoE         |
| 2   | DM-NVX-360              | DM NVX Network AV Encoder/Decoder             |
| 1   | DMPS3-4K-350-C-AIRMEDIA | 3-Series® 4K DigitalMedia Presentation System |
| 1   | HD-RX-101-C-E           | DM Lite® Receiver with HDMI over CATx         |
| 1   | PW-5430DUS              | High-Efficiency Power Pack                    |
| 4   | SAROS IC8T-W-T-EACH     | Saros® 8" 2-Way In-Ceiling Speaker            |

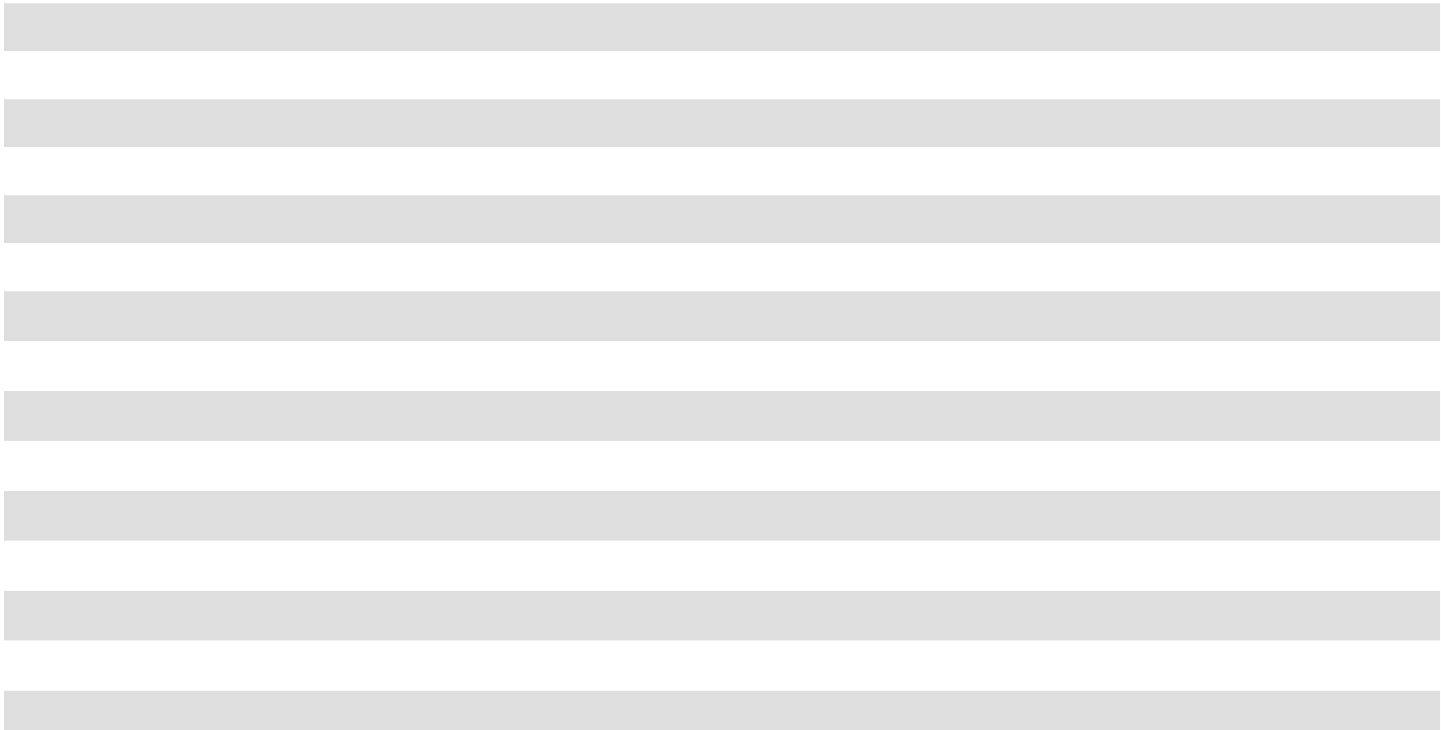

Rack

Ceiling

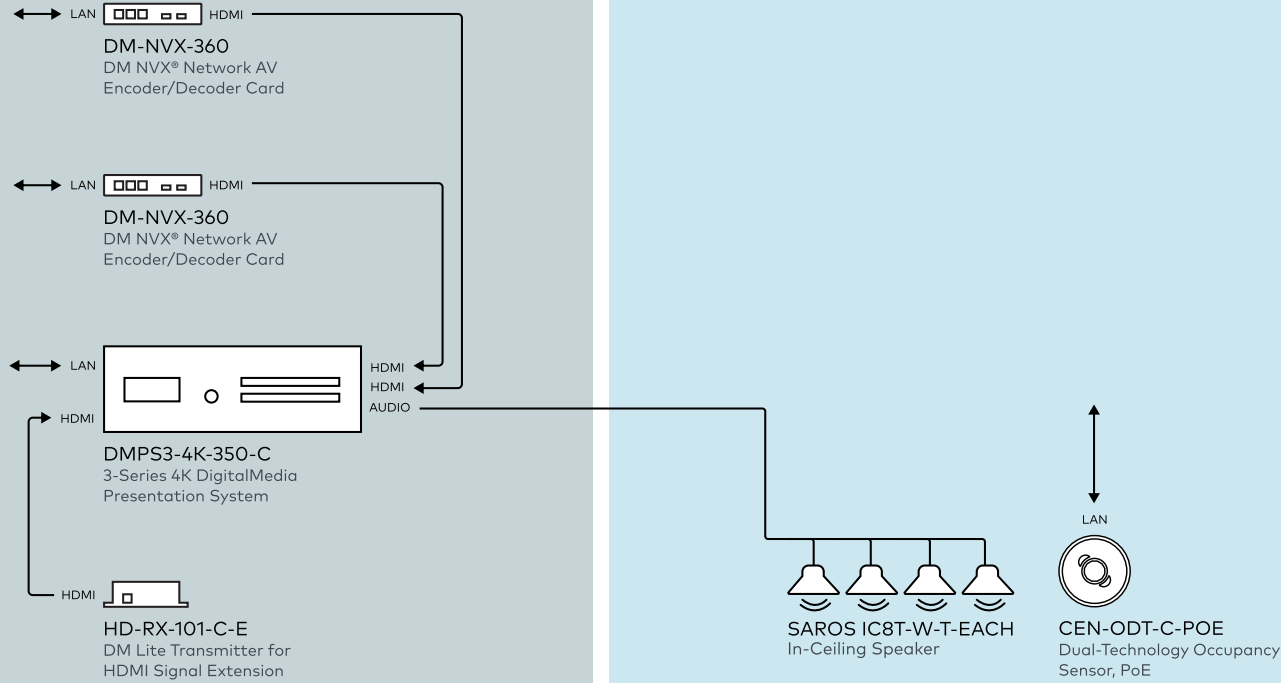

## JURY SELECTION ROOM

### TOTAL SOLUTION

#### Bill of Materials

| Qty | Model Number        | Description   |
|-----|---------------------|---|
| 1   | AM-3200             | AirMedia Presentation System 3200   |
| 1   | AMP-8075            | 8-Channel Power Amplifier   |
| 1   | CP4N                | 4-Series Control System   |
| 1   | DGE-100             | Digital Graphics Engine 100   |
| 1   | DM-DGE-200-C        | Digital Graphics Engine 200   |
| 27  | DM-NVX-360          | DM NVX Network AV Encoder/Decoder   |
| 5   | DM-NVX-360C         | DM NVX Network AV Encoder/Decoder Card  |
| 1   | DM-NVX-DIR-80       | DM NVX Director® Virtual Switching Appliance  |
| 1   | DMF-CI-8            | DigitalMedia Card Chassis   |
| 4   | FT2-500-MECH-PTL-B  | FlipTop™ FT2 Series Cable Management System   |
| 4   | FT2A-CBL-PT-4K-HD   | Pass-Through Cable for FT2 Series   |
| 4   | FT2A-CBL-PT-CAT6    | Pass-Through Cable for FT2 Series   |
| 1   | FT2A-PLT-BLANK-10   | FlipTop™ FT2 Series Cable Management System Blank Plate                               |
| 1   | FT2A-PLT-PT-10      | FlipTop™ FT2 Series Cable Management System Cable Pass-Through Plate                  |
| 4   | FT2A-PWR-US-1-BASIC | AC Power Outlet Module for FT2 Series   |
| 12  | SAROS IC8T-W-T-EACH | Saros 8" 2-Way In-Ceiling Speaker   |
| 1   | TSD-2220-B          | 21.5" HD Touch Screen   |
| 1   | TSS-1070-B-S-LB KIT | 10.1 in. Room Scheduling Touch Screen   |
| 1   | UC-C100-T           | Crestron Flex UC Video Conference System Integrator Kit for Microsoft Teams® Software |
| 1   | UC-FLEXCARE-C       | Premium Crestron Flex Support   |

Full-featured room with presentation and videoconferencing.

#### System Features

FlipTop touch screen control at tables and lectern

Full-featured switching design using DM NVX AV-over-IP and DM NVX Director virtual switching appliance

Wireless presentation capability

Multiple display support

Remote video conferencing capability

Touch screen control at entrance and lectern locations

Room scheduling

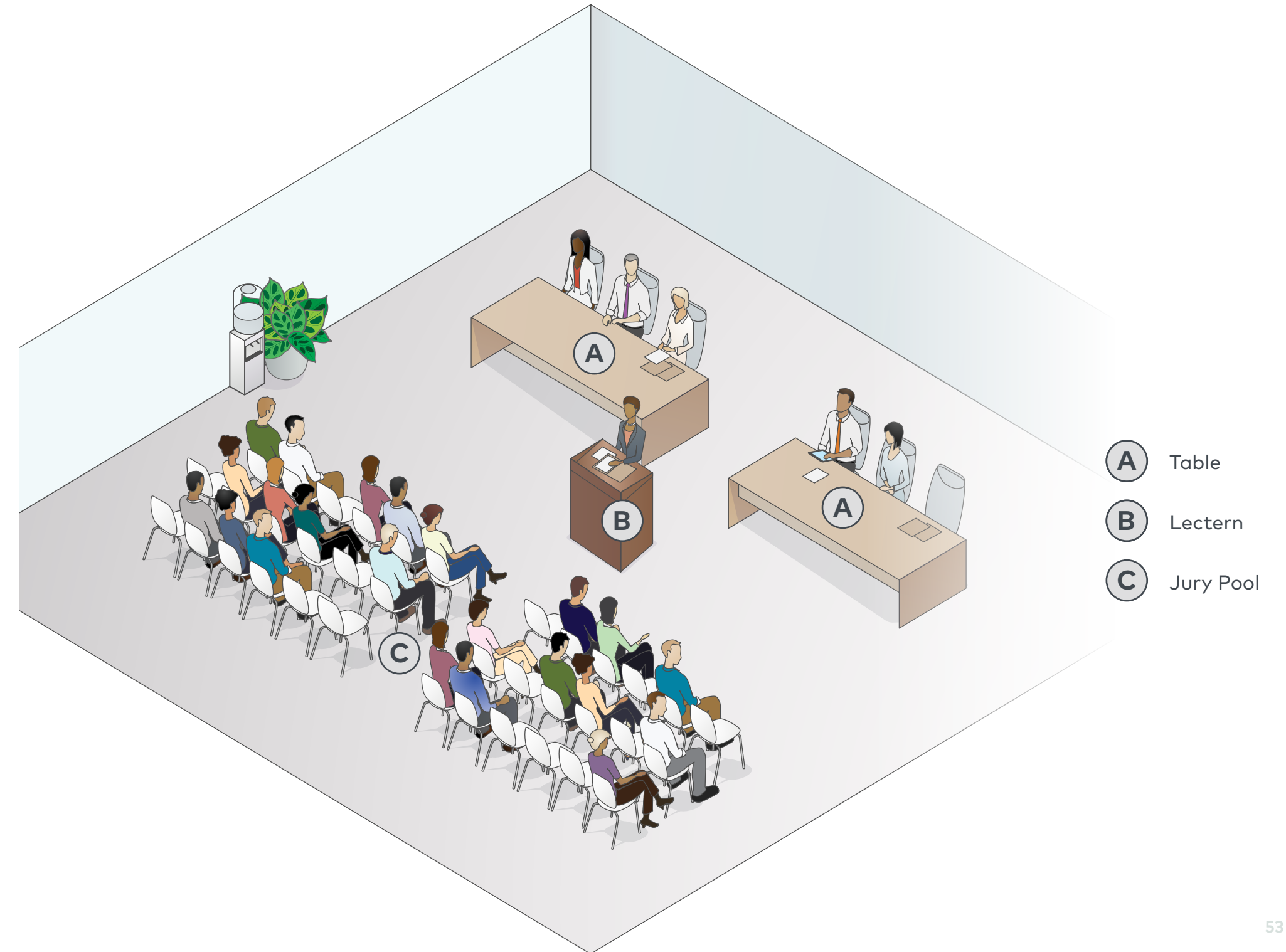

- A** Table
- B** Lectern
- C** Jury Pool

JURY SELECTION ROOM

LECTERN, TABLE, & FRONT ENTRANCE

Bill of Materials

| Qty | Model Number        | Description                                 |
|-----|---------------------|---|
| 5   | DM-NVX-360          | DM NVX Network AV Encoder/Decoder           |
| 2   | FT2-500-MECH-PTL-B  | FlipTop™ FT2 Series Cable Management System |
| 2   | FT2A-CBL-PT-4K-HD   | Pass-Through Cable for FT2 Series           |
| 2   | FT2A-CBL-PT-CAT6    | Pass-Through Cable for FT2 Series           |
| 2   | FT2A-PWR-US-1-BASIC | AC Power Outlet Module for FT2 Series       |
| 1   | TSS-1070-B-S-LB KIT | 10.1 in. Room Scheduling Touch Screen       |

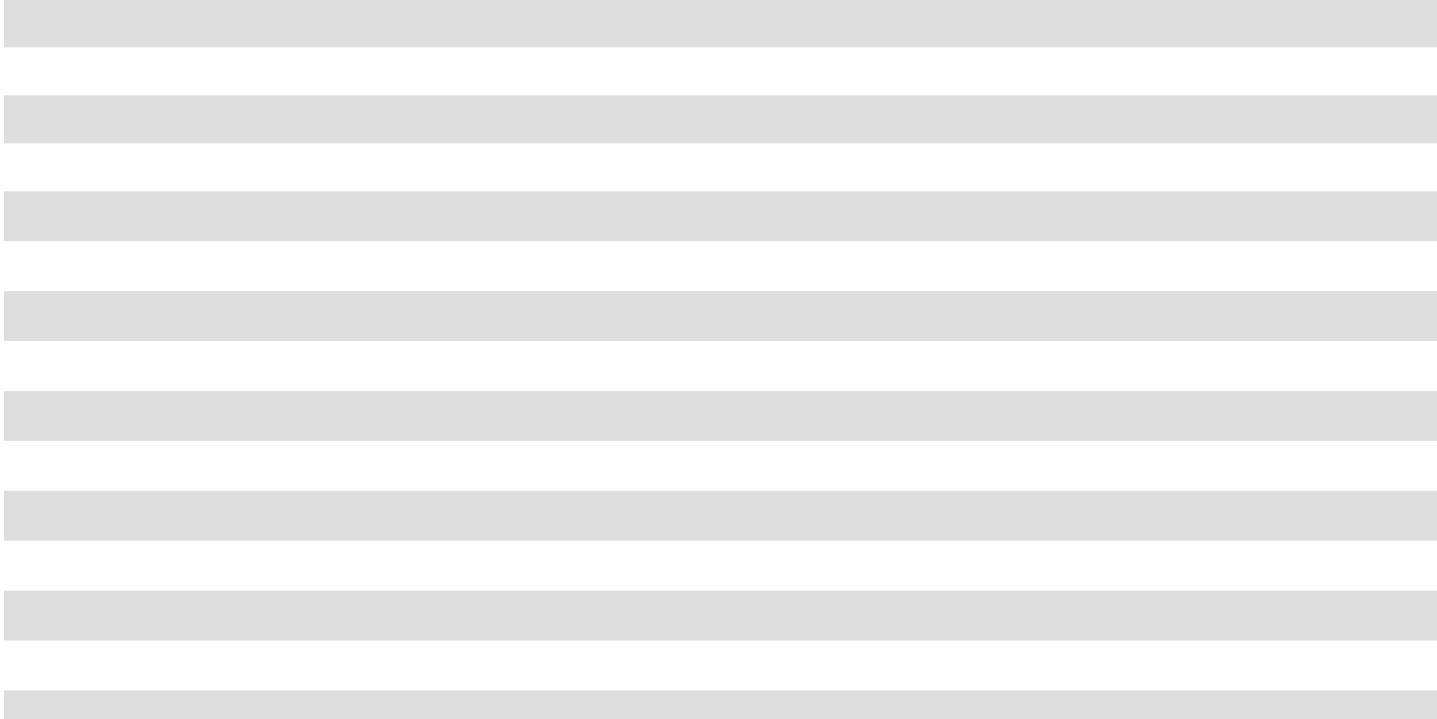

Lectern

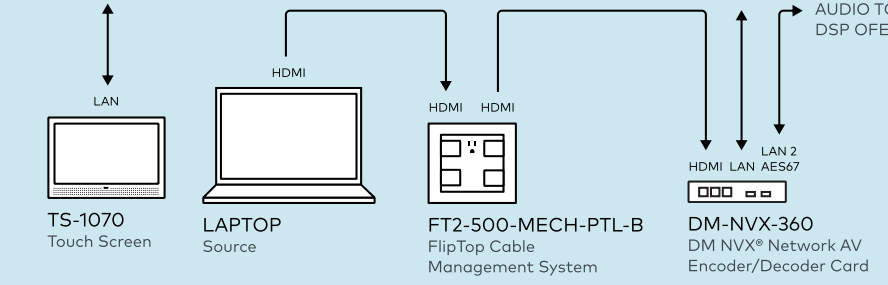

Table

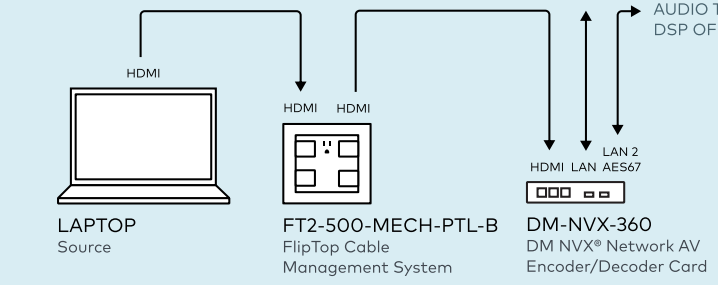

X3

Front Entrance

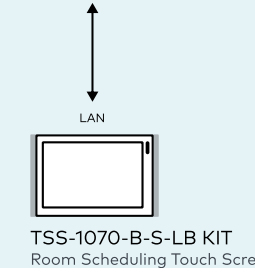



# JURY SELECTION ROOM

## WALL & FRONT OF ROOM

### Bill of Materials

| Qty | Model Number | Description                       |
|-----|--------------|-----------------------------------|
| 1   | DM-DGE-200-C | Digital Graphics Engine 200       |
| 2   | DM-NVX-360   | DM NVX Network AV Encoder/Decoder |
| 1   | TSD-2220-B   | 21.5" HD Touch Screen             |

Wall

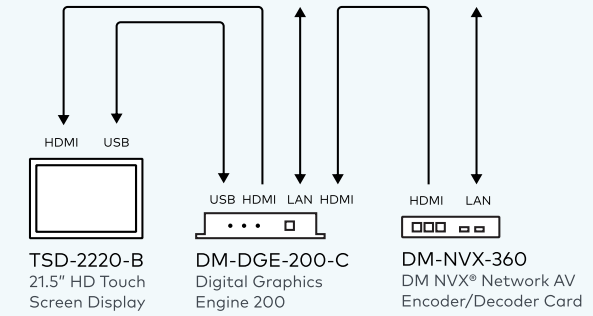

Front of Room

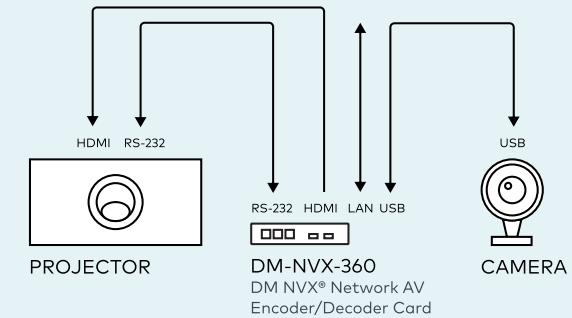



# JURY SELECTION ROOM

## RACK & CEILING

### Bill of Materials

| Qty | Model Number        | Description   |
|-----|---------------------|---|
| 1   | AM-3200             | AirMedia Presentation System 3200   |
| 1   | AMP-8075            | 8-Channel Power Amplifier   |
| 1   | CP4N                | 4-Series Control System   |
| 1   | DGE-100             | Digital Graphics Engine 100   |
| 1   | DM-DGE-200-C        | Digital Graphics Engine 200   |
| 7   | DM-NVX-360          | DM NVX Network AV Encoder/Decoder   |
| 5   | DM-NVX-360C         | DM NVX Network AV Encoder/Decoder Card  |
| 1   | DM-NVX-DIR-80       | DM NVX Director® Virtual Switching Appliance                                  |
| 1   | DMF-CI-8            | DigitalMedia Card Chassis   |
| 12  | SAROS IC8T-W-T-EACH | Saros® 8" 2-Way In-Ceiling Speaker  |
| 1   | UC-C100-T           | Crestron Flex Video Conference System Integrator Kit for Microsoft Team Rooms |
| 1   | UC-FLEXCARE-C       | Premium Crestron Flex Support   |

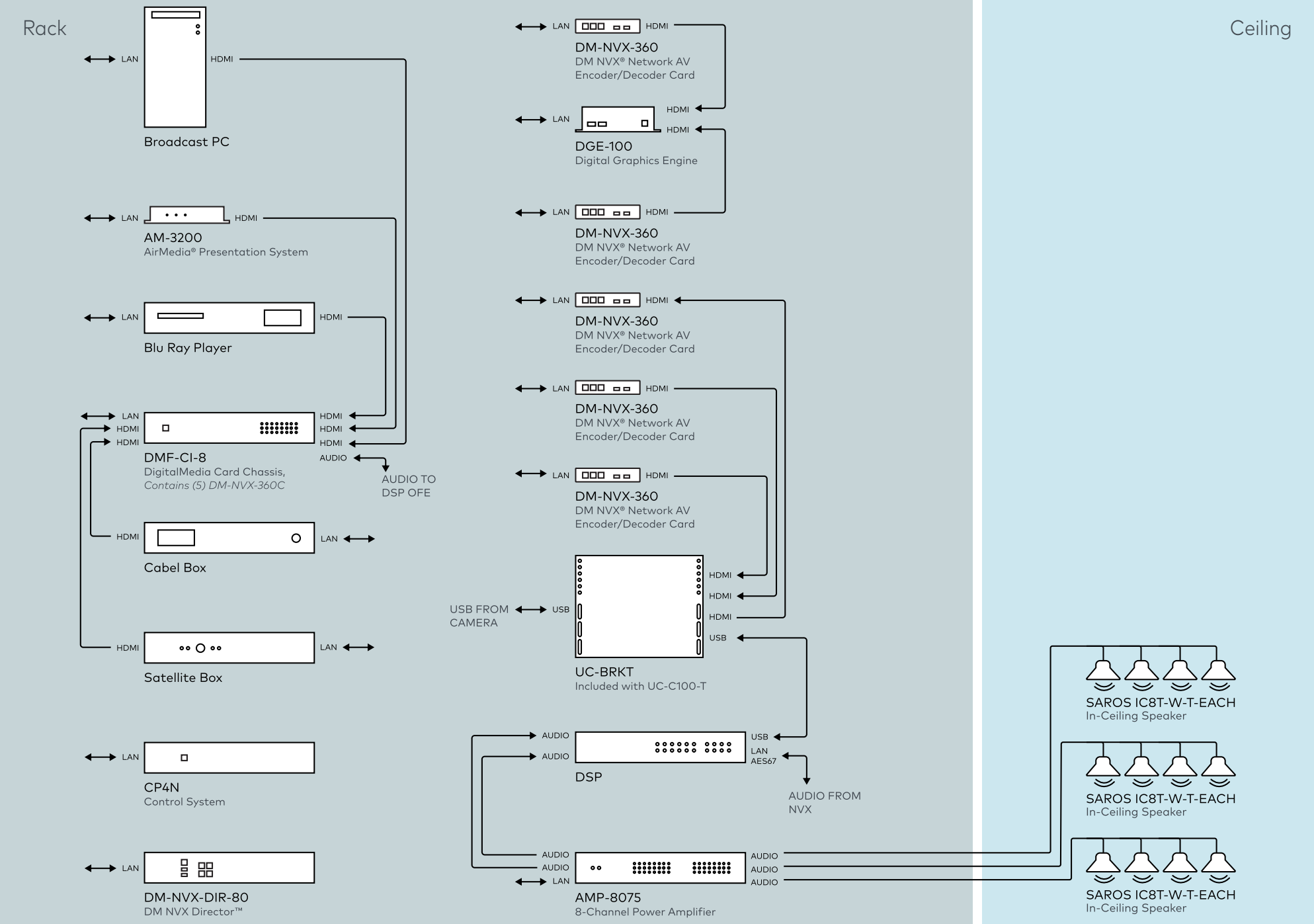



## JUDGES' CHAMBERS

### TOTAL SOLUTION

#### Bill of Materials

| Qty | Model Number           | Description  |
|-----|------------------------|--|
| 1   | AM-3200                | AirMedia® Series 3 Receiver 200  |
| 1   | AMP-X50MP              | X Series Media Presentation Amplifier  |
| 1   | DM-NVX-360             | DM NVX Network AV Encoder/Decoder  |
| 1   | FT2-500-MECH-PTL-B     | FlipTop™ FT2 Series Cable Management System  |
| 1   | FT2A-CBL-PT-4K-HD      | Pass-Through Cable for FT2 Series, HDMI® to HDMI   |
| 1   | FT2A-CBL-PT-4K-USBC-HD | Pass-Through Cable for FT2 Series, USB-C® to HDMI®   |
| 1   | FT2A-CBL-PT-CAT6       | Pass-Through Cable for FT2 Series, RJ-45 to RJ-45, CAT6  |
| 1   | FT2A-PLT-BLANK-10      | FlipTop™ FT2 Series Cable Management System  |
| 1   | FT2A-PLT-PT-10         | FlipTop™ FT2 Series Cable Management System  |
| 1   | FT2A-PWR-US-1-BASIC    | AC Power Outlet Module for FT2 Series  |
| 2   | HD-TX-101-C-1G-E-B-T   | DM Lite® Transmitter for HDMI® Signal Extension over CATx Cable, Wall Plate, Black Textured                  |
| 1   | HD-RX-4K-510-C-E-SW4   | DMPS Lite™ 4K Multiformat 5x1 AV Switch and Receiver with 4-Port Ethernet Switch                             |
| 1   | HD-TX-301-C-E          | DM Lite® Transmitter and 3x1 Auto-Switcher for HDMI®, VGA, and Analog Audio Signal Extension over CATx Cable |
| 1   | RMC4                   | 4-Series™ Control System   |
| 4   | SAROS IC6T-W-T-EACH    | Saros® 6.2" 2-Way In-Ceiling Speaker   |
| 1   | UC-C100-T              | Crestron Flex Video Conference System Integrator Kit for Microsoft Teams® Rooms                              |
| 1   | UC-FLEXCARE-C          | Premium Crestron Flex Support  |

Low-cost conference room featuring presentation and video conferencing.

#### System Features

FlipTop touch screen control

All-in-one HDBaseT presentation switcher

Single display support

Touch screen control at table



- A** Desk
- B** Table

# JUDGES' CHAMBERS

## DESK & WALL Bill of Materials

| Qty | Model Number         | Description  |
|-----|----------------------|--|
| 1   | FT2-500-MECH-PTL-B   | FlipTop™ FT2 Series Cable Management System  |
| 1   | FT2A-CBL-PT-4K-HD    | Pass-Through Cable for FT2 Series  |
| 1   | FT2A-CBL-PT-CAT6     | Pass-Through Cable for FT2 Series  |
| 1   | FT2A-PWR-US-1-BASIC  | AC Power Outlet Module for FT2 Series  |
| 1   | HD-RX-4K-510-C-E-SW4 | DMPS Lite™ 4K Multiformat 5x1 AV Switch and Receiver with 4-Port Ethernet Switch                             |
| 2   | HD-TX-101-C-1G-E-B-T | DM Lite® Transmitter for HDMI® Signal Extension over CATx Cable, Wall Plate                                  |
| 1   | HD-TX-301-C-E        | DM Lite® Transmitter and 3x1 Auto-Switcher for HDMI®, VGA, and Analog Audio Signal Extension over CATx Cable |
| 1   | TSW-1070-B-S         | Included with UC-C100-T  |

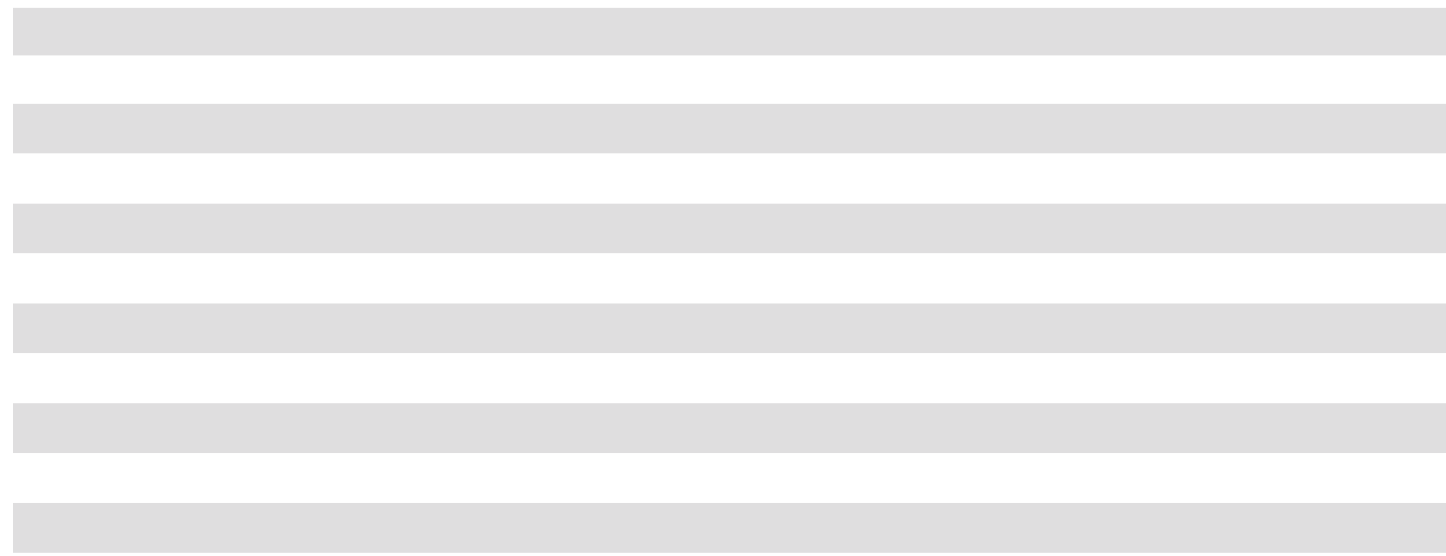

Desk

Equipment Location

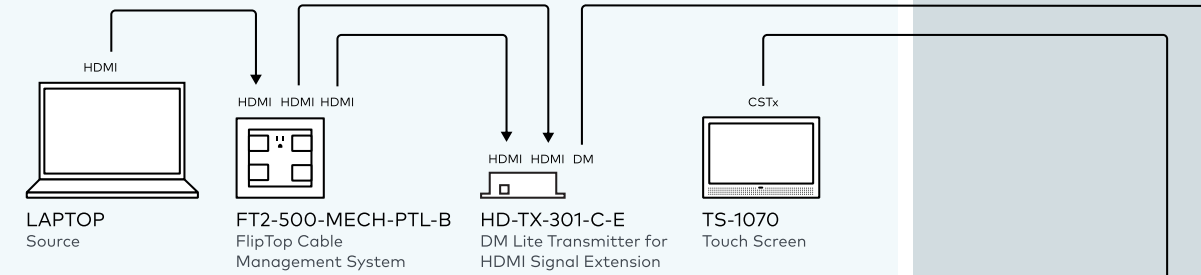

Table

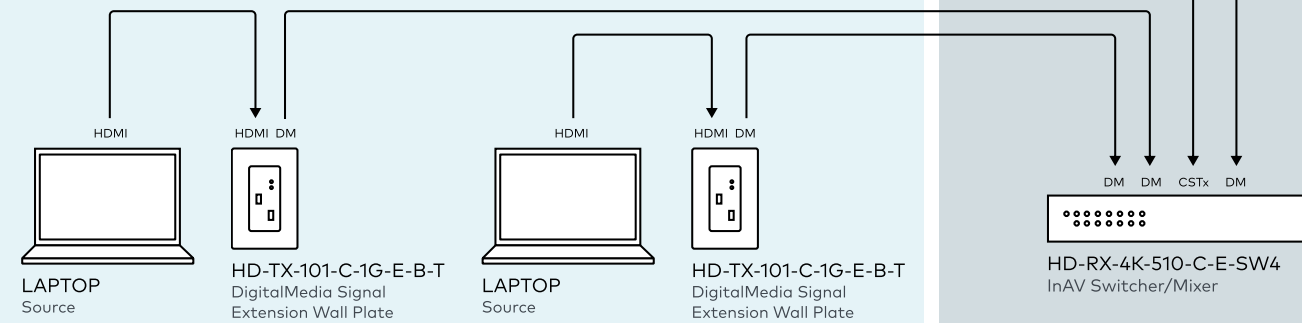

# JUDGES' CHAMBERS

## EQUIPMENT LOCATION & CEILING

### Bill of Materials

| Qty | Model Number         | Description  |
|-----|----------------------|--|
| 1   | AM-3200              | AirMedia® Series 3 Receiver 200  |
| 1   | AMP-X50MP            | X Series Media Presentation Amplifier  |
| 1   | DM-NVX-360           | DM NVX Network AV Encoder/Decoder  |
| 1   | HD-RX-4K-510-C-E-SW4 | DMPS Lite™ 4K Multiformat 5x1 AV Switch and Receiver with 4-Port Ethernet Switch |
| 1   | RMC4                 | 4-Series Control System  |
| 4   | SAROS IC6T-W-T-EACH  | Saros 6.2" 2-Way In-Ceiling Speaker  |
| 1   | UC-C100-T            | Crestron Flex Video Conference System Integrator Kit for Microsoft Teams® Rooms  |
| 1   | UC-FLEXCARE-C        | Premium Crestron Flex Support  |

### Equipment Location

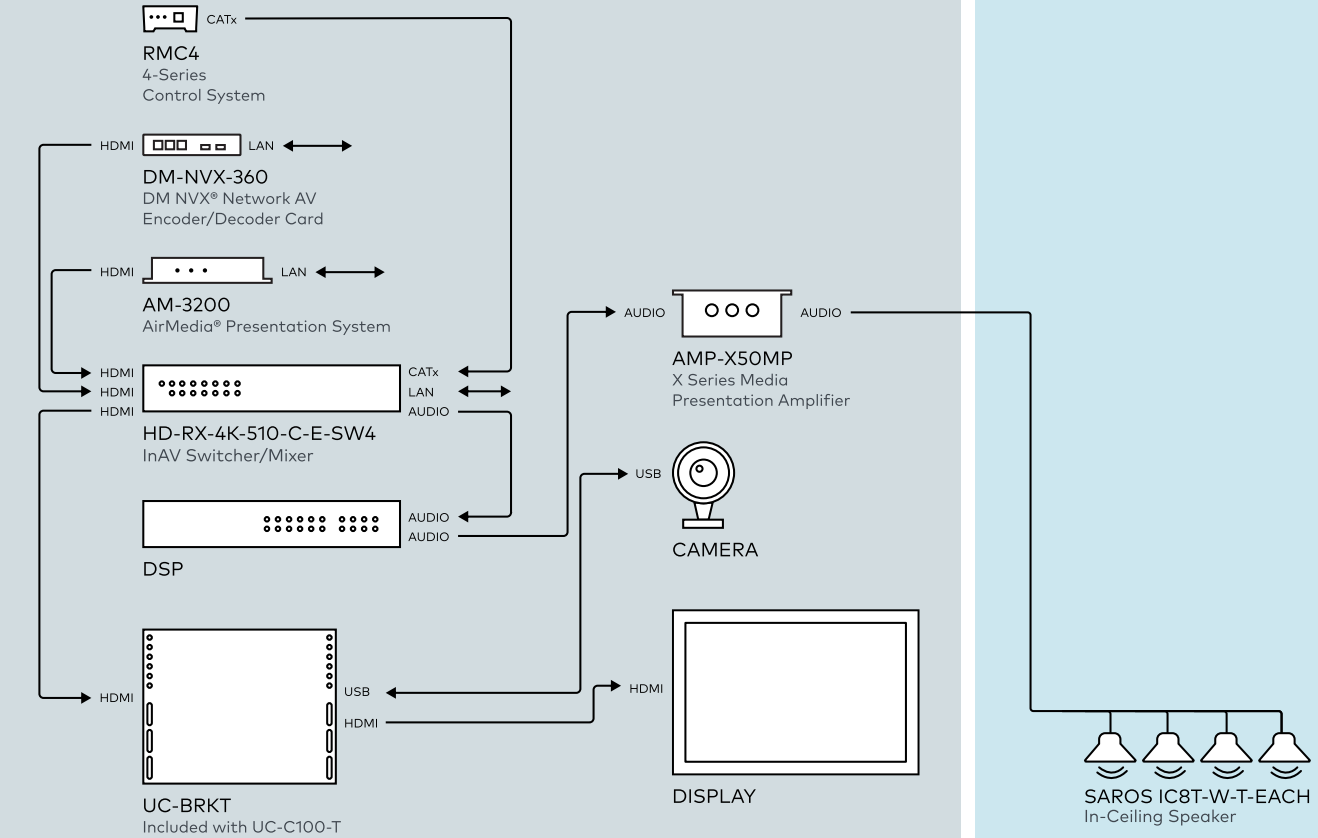



Contact us for more information | [crestron.com/government](https://crestron.com/government) | Crestron 24/7/365 True Blue Support  
888.273.7876 | Crestron Technical Design Assistance 800.237.2041

#### **World Headquarters**

15 Volvo Drive  
Rockleigh, NJ 07647  
800.237.2041  
201.767.3400  
[crestron.com](https://crestron.com)

#### **Latin America**

Blvd. Manuel Avila Camacho 37-1A  
Col. Lomas de Chapultepec  
CP 11560  
México  
+52 (55) 9159.5900  
+ (305) 290.4978  
[crestron.com.mx](https://crestron.com.mx)

#### **Crestron Europe B.V.**

Oude Keerbergsebaan 2  
B-2820  
Rijmenam  
Belgium  
+32.15.50.99.50  
[crestron.com](https://crestron.com)

#### **Australia**

Level 5  
15 Help Street  
Chatswood NSW 2067  
Australia  
+61.1800.555.040  
[ANZHQ@crestron.com](mailto:ANZHQ@crestron.com)  
[crestron.com](https://crestron.com)

#### **New Zealand**

Unit 18  
144-160 Beaumont Street  
Westhaven, Auckland 1010  
New Zealand  
+64.800.273.787  
[ANZHQ@crestron.com](mailto:ANZHQ@crestron.com)  
[crestron.com](https://crestron.com)

#### **Israel**

14 Hata'as Street  
Kfar Saba, 4442514  
Israel  
+972.9.7685556  
[crestron.co.il](https://crestron.co.il)

#### **India**

Unit 101 & 102 RMZ Ecoworld  
Campus 6B Sarjapur Marathalli  
Outer Ring Road  
Bangalore 560103  
1.800.3005.8822  
[INDIASalessupport@crestron.com](mailto:INDIASalessupport@crestron.com)  
[crestron.com](https://crestron.com)

#### **NE Asia**

Suite 3101-02, 31/F Oxford House,  
Taikoo Place 979 Kings Road  
Hong Kong  
+852 800 969 996  
[NEAsalessupport@crestron.com](mailto:NEAsalessupport@crestron.com)  
[crestron.com](https://crestron.com)

#### **China**

487 Tian Lin Road Gems Park  
Block 25 Xu Hui District  
P.R.C. Shanghai 200233  
Toll Free Phone: 400.880.9700

#### **SE Asia**

30 Cecil St  
#21-05, Prudential Tower  
Singapore 049712  
+65.6932.1020  
[crestron.com](https://crestron.com)

#### **Japan**

1736-3 Higashitsuda-Cho  
Matsue City 690-0011  
Japan  
+81.852.60.5185  
[crestronjapan.com](https://crestronjapan.com)

#### **South Africa**

Hampton Office Park Atterbury House  
20 Georgian Crescent East Bryanston  
Johannesburg  
South Africa

