



# Crestron Shading Solutions Roller Shade and Drapery Track Systems

Design Guide  
Crestron Electronics, Inc.

**Original Instructions**

The U.S. English version of this document is the original instructions.  
All other languages are a translation of the original instructions.

Crestron product development software is licensed to Crestron dealers and Crestron Service Providers (CSPs) under a limited nonexclusive, nontransferable Software Development Tools License Agreement. Crestron product operating system software is licensed to Crestron dealers, CSPs, and end-users under a separate End-User License Agreement. Both of these Agreements can be found on the Crestron website at [www.crestron.com/legal/software\\_license\\_agreement](http://www.crestron.com/legal/software_license_agreement).

The product warranty can be found at [www.crestron.com/warranty](http://www.crestron.com/warranty).

The specific patents that cover Crestron products are listed at [www.crestron.com/legal/patents](http://www.crestron.com/legal/patents).

Certain Crestron products contain open source software. For specific information, visit [www.crestron.com/opensource](http://www.crestron.com/opensource).

Crestron, the Crestron logo, Cresnet, infiNET EX, QMT, and Quiet Motor Technology are either trademarks or registered trademarks of Crestron Electronics, Inc. in the United States and/or other countries. Hartmann&Forbes is either a trademark or a registered trademark of Hartmann & Forbes, Inc. in the United States and/or other countries. PANTONE is either a trademark or a registered trademark of Pantone, Inc. in the United States and/or other countries. Other trademarks, registered trademarks, and trade names may be used in this document to refer to either the entities claiming the marks and names or their products. Crestron disclaims any proprietary interest in the marks and names of others. Crestron is not responsible for errors in typography or photography.

©2022 Crestron Electronics, Inc.

# Contents

<b>Overview</b> .....	<b>1</b>
Purpose of This Guide .....	1
Crestron Shading Solutions Benefits .....	1
Daylight Control .....	1
Security and Privacy .....	1
Quiet Shade Motors .....	2
Brushless Motor Technology .....	2
Easy Installation .....	2
Right Size Guarantee .....	2
Crestron Shading Solutions Limited Warranty .....	2
Color Match .....	2
Pattern Print .....	3
<b>Design Resources</b> .....	<b>4</b>
Crestron Design Tool Shades (CDTS) Software .....	4
Hardware Sample Case .....	4
Crestron Shade Fabrics .....	5
Shade Fabric Book Collection .....	5
Shade Fabric Sample Decks .....	6
Crestron and Hartmann&Forbes® Artisanal Shading Textiles Sample Box .....	6
Crestron Horizontal Sheer Fabric Sample Binder .....	7
<b>Crestron Roller Shades</b> .....	<b>8</b>
Crestron Roller Shade Options .....	9
Digital QMT Roller Shade Motors .....	12
3/4 Nm Motors .....	12
4 Nm Motors .....	13
Manual Clutch .....	13
Roller Shade Mounting Brackets .....	14
QMT3 Series Architectural Brackets .....	14
QMT5 Series Architectural Brackets .....	15
QMT3 Series Décor Brackets .....	17
QMT5 Series Décor Brackets .....	17
Roller Shade Tube Options .....	19
Roller Shade Mounting Options .....	20
Inside Mount .....	20
Outside Mount .....	21
Pocket Mount .....	22
Roller Shade Accessories .....	23
Blackout Accessories .....	23
Fascia Options .....	25

End Cap Options .....	26
Top and Back Cover .....	26
Pocket .....	27
Roller Shade Fabrics and Textiles .....	28
Fabric Characteristics .....	28
Fenestration Data .....	29
Hem Bar Styles .....	30
Fabric Railroading .....	31
Specialty Roller Shades .....	33
Battery-Powered Shades .....	33
Crestron Horizontal Sheers .....	34
Roman Shades .....	34
Cable Guided Shades .....	35
Roller Shade Measuring Guidelines .....	36
How to Measure Single Roller and In-Line Coupled Roller Shades .....	36
How to Measure Angled Coupled Shades .....	37
Installation Dimensions .....	38
QMT3 Series Architectural Brackets .....	38
QMT5 Series Architectural Brackets .....	42
QMT3 Series Décor Bracket .....	44
QMT5 Series Décor Brackets .....	45
Creating Custom Pockets for QMT3 Series Architectural Brackets .....	46
Creating Custom Pockets for QMT5 Series Architectural Brackets .....	48
<b>Crestron Drapery Track .....</b>	<b>50</b>
Determining the Proper Drapery Track System .....	51
Mounting Options .....	52
Ceiling Mount .....	52
Wall Bracket .....	52
Pocket Mount .....	53
Arm Types .....	54
Splicing .....	55
Track Styles .....	56
Straight Track .....	56
Bent Track .....	56
Curved Track .....	58
Fabric Types .....	59
Pinch Pleat .....	59
Ripplefold .....	59
Draw Types .....	60
Measuring Guidelines .....	62
Dimensions .....	63
Arm Dimensions .....	63
Drapery Track Ceiling Mount Configurations .....	65

Drapery Track Wall Mount Configurations .....	69
<b>Designing and Specifying .....</b>	<b>73</b>
<b>Programming .....</b>	<b>74</b>
<b>Wiring and Power .....</b>	<b>75</b>
Wiring .....	75
Power Supplies .....	75
Single-Motor Power Supply .....	75
Ten-Motor Power Supply .....	76
<b>Ordering Guidelines .....</b>	<b>77</b>
<b>Installation Guidelines .....</b>	<b>78</b>
<b>Shipping and Receiving Shades .....</b>	<b>79</b>
<b>Fabric Care and Maintenance .....</b>	<b>80</b>
How to Clean Fabric .....	80
Roller Shade Fabric Edge Fray .....	80
Detailing the Cut Edges .....	80
Minimizing Fraying .....	80
<b>Glossary .....</b>	<b>81</b>
<b>Resources .....</b>	<b>83</b>
Crestron Support and Training .....	83
Programmer and Developer Resources .....	83
Product Certificates .....	83
Related Documentation .....	83



# Overview

Crestron brings the same engineering excellence from its advanced control and automation solutions to its shading product line, providing precise, quiet one-touch daylight management with a complete line of motorized window shades and drapery track systems. Shading systems allow the customer to easily regulate the natural light in a room with a simple touch of a button. Shades are energy efficient and provide UV protection, glare control, and privacy at a competitive cost.

## Purpose of This Guide

This design guide includes the following:

- How to select the correct shade or drape system for the application.
- How to measure for proper installation.
- Detailed views of product design specifications (with dimensions) for the Décor as well as Architectural mounting brackets and drapery track systems in a variety of configurations.
- Overview of the fabric styles.
- How to select fabric based on application.
- How to care for the fabric.
- Information on fabric types and how to use the fabric binder.
- How to select a power supply.
- Overview for integrating shades and drapery track systems with Crestron control systems.

## Crestron Shading Solutions Benefits

### Daylight Control

Protect fine furnishings and floor coverings from harmful UV rays with intelligent shading solutions. Shades can track the rising and setting of the sun to prevent extra solar heat gain in the summer and utilize its warmth in the winter for added energy efficiency. Crestron shades can also work with an entertainment system to close shades and prevent glare on a TV when it is turned on, automatically creating the ideal viewing scenario.

### Security and Privacy

Automated shades provide privacy and security. Shades allow natural light in with semi-translucent shades, or use blackout shades to completely block views. In the event of a

forced entry into a home, shades integrated with a security system can be set to raise automatically, allowing an intruder to be easily spotted from the outside.

## Quiet Shade Motors

Crestron automated shades feature low-voltage Digital QMT® shade motors for quiet operation. Crestron shades help manage daylight without audible disruptions to the space. For details, refer to [Digital QMT Roller Shade Motors \(on page 12\)](#).

## Brushless Motor Technology

The Crestron Digital QMT shade motor is a brushless design, which translates into exceptional reliability, smoother operation, and ultra-quiet performance.

## Easy Installation

Crestron shades are easy to install. Brackets are easily mounted, and the motor clicks into place with no special tools required.

## Right Size Guarantee

The Crestron Right Size Guarantee (RSG) enables Crestron's authorized resellers in selected countries to confidently measure their customers' space for custom residential shading solutions without the worry of making a mistake. A simple measuring mishap need not result in extra costs to replace the incorrectly measured shade. If the requested replacement qualifies for the terms of the Right Size Guarantee, Crestron will not charge its authorized resellers for the replacement shade. For more information, refer to [crestron.com/Legal/ShadesRightSizeGuarantee](https://crestron.com/Legal/ShadesRightSizeGuarantee).

## Crestron Shading Solutions Limited Warranty

The limited warranty is applicable to Crestron Shading Solutions mounting hardware, shade fabric, Digital QMT shade motors, and QMT shade motors only. For more information, refer to the [Crestron Shading Solutions Limited Warranty](#).

## Color Match

With Crestron's exclusive Color Match service, roller shades are now available in any color. Simply provide a Pantone® color code or a physical color sample and Crestron will do the rest. Shades can be integrated perfectly into the customers' design schemes.

The Crestron Color Match service is ready and available in the Crestron Design Tool (CDT) for both motorized and manual roller shades. It is available in fabrics with openness factors of 1, 3, 5, and 10% as well as blackout shades. For more information, email the Crestron Color Match Service at [colormatch@crestron.com](mailto:colormatch@crestron.com).



## Pattern Print

Create a custom look by printing custom graphics and logos directly on shade fabric. Custom prints are submitted through the Crestron Design Tool (CDT).

# Design Resources

Crestron provides the following tools and resources to assist the user when designing shade and drapery track systems.

## Crestron Design Tool Shades (CDTS) Software

The [Crestron Design Tool Shades \(CDTS\)](#) is a web-based tool used for quoting and ordering Crestron roller shades and drapery tracks. The software may be used to easily create proposals for customers and place orders directly to Crestron.

## Hardware Sample Case

Crestron offers two hardware sample cases that display all mounting brackets and accessories for the QMT3 series ([CSA-DSK-HDWR-QMT3](#)) and QMT5 series ([CSA-DSK-HDWR-QMT5](#)) shade hardware.

The sample cases contain brackets, end caps, fascia, and accessories for each series. Also included is a variety of color chips that show the various colors that the components are available in.



# Crestron Shade Fabrics

These Shade Fabric resources are available:

- [Shade Fabric Book Collection \(below\)](#)
- [Shade Fabric Sample Decks \(on the next page\)](#)
- [Crestron and Hartmann&Forbes® Artisanal Shading Textiles Sample Box \(on the next page\)](#)
- [Crestron Horizontal Sheer Fabric Sample Binder \(on page 7\)](#)

## Shade Fabric Book Collection



The Crestron® Shade Fabric Book Collection ([CSF-FABRIC-COLLECTION](#)) elegantly displays the complete line of Crestron shade fabrics. Our Heritage, Designer, and Horizontal Sheers collections are each organized and presented in three separate stylized binders. Neatly store and transport all of the required shade fabric material using the included satchel — perfect for taking on the go to site visits and client consultations.

## Shade Fabric Sample Decks



The Crestron® Shade Fabric Sample Decks ([CSF-FABRIC-COLLECTION-DECK-01](#)) compliment the Heritage and Designer fabric books by providing larger, 4.5 by 9-inch fabric samples. The CSF-FABRIC-COLLECTION-DECK-01 provides six fabric sample decks; three fabric sample decks for the Heritage fabric book and three fabric sample decks for the Designer fabric book.

The Heritage fabric decks are separated into solar, dual-sided, and eco-friendly fabric decks while the Designer fabric decks are separated into sheer, light-filtering, blackout decks.

## Crestron and Hartmann&Forbes® Artisanal Shading Textiles Sample Box

The Crestron and Hartmann&Forbes Artisanal Shading Textiles Sample Box ([CSF-SB-ROLLER-HF](#)) is a collection of hand-woven textiles designed for Crestron roller shade systems. The textiles feature natural fibers that are sustainably grown and artfully hand loomed.

The sample box contains a variety of 6 x 5 in. premium textile samples grouped by color story from pure white to rich chocolate browns and grays.



## Crestron Horizontal Sheer Fabric Sample Binder



The Crestron Horizontal Sheer Fabric Sample Binder ([CSF-FABRIC-COLLECTION-HSHEER](#)) elegantly displays the horizontal sheer fabric collections in a highly stylized, eye-catching binder. The binder contains a variety of colors to suit shading needs and makes it easy to envision a particular roller shade fabric in a room. Information about the fabric is printed on the back of each sample card, including its fabric number and fenestration data.

# Crestron Roller Shades

Crestron Shade Solutions offers a variety of components to assemble a roller shade that fits any application. Refer to the following sections for an overview of the available components for a Crestron Roller shade:

- [Crestron Roller Shade Options \(on the facing page\)](#)
- [Digital QMT Roller Shade Motors \(on page 12\)](#)
- [Roller Shade Mounting Brackets \(on page 14\)](#)
- [Roller Shade Tube Options \(on page 19\)](#)
- [Roller Shade Mounting Options \(on page 20\)](#)
- [Roller Shade Accessories \(on page 23\)](#)
- [Roller Shade Fabrics and Textiles \(on page 28\)](#)
- [Specialty Roller Shades \(on page 33\)](#)
- [Roller Shade Measuring Guidelines \(on page 36\)](#)
- [Installation Dimensions \(on page 38\)](#)

# Crestron Roller Shade Options

	CS-SHADE-ROLLER				CS-SHADE-ROLLER-BATT		CS-SHADE-ROMAN	CS-SHADE-ROLLER-HSHEER	CS-SHADE-ROLLER-CABLEGUIDED	
Compatible Bracket:	CSA-ARCH5	CSA-ARCH3	CSA-DECOR5	CSA-DECOR3	CSA-ARCH3	CSA-DECOR3	CSA-DECOR5	CSA-ARCH3	CSA-ARCH5	CSA-DECOR5
<b>Mounting Style</b>										
Single Roll	✓	✓	✓	✓	✓	✓	✓	✓	✓	✓
Dual Roll	✓	✓								
Coupled	✓		✓							
Exposed Brackets			✓	✓		✓				
Exposed Fabric Roll			✓	✓		✓				
<b>Mounting Location</b>										
Inside Mount	✓	✓			✓	✓	✓	✓	✓	✓
Outside Mount	✓	✓	✓	✓	✓	✓	✓	✓	✓	✓
<b>Crestron Pocket</b>										
Single Pocket	✓	✓								
Dual Pocket		✓								
<b>Hem bar Options</b>										
	Open Pocket, Open Pocket with End Caps, Sealed Pocket, Exposed Blackout		Open Pocket, Open Pocket with End Caps, Sealed Pocket, Exposed Blackout		Open Pocket, Open Pocket with End Caps, Sealed Pocket, Exposed Blackout		N/A	Bottom Slat		
<b>Fascia</b>										
	✓	✓	N/A	N/A	✓	N/A	N/A	✓	✓	
	Square or Round	Square or Round			Square or Round			With or without fabric insert		
<b>Blackout Accessories</b>										
	✓	✓			✓					

	CS-SHADE-ROLLER				CS-SHADE-ROLLER-BATT		CS-SHADE-ROMAN	CS-SHADE-ROLLER-HSHEER	CS-SHADE-ROLLER-CABLEGUIDED	
Compatible Bracket:	CSA-ARCH5	CSA-ARCH3	CSA-DECOR5	CSA-DECOR3	CSA-ARCH3	CSA-DECOR3	CSA-DECOR5	CSA-ARCH3	CSA-ARCH5	CSA-DECOR5
<b>Color/Finish Options</b>	White, Brown, Gray, Black, Almond		White, Brown, Gray, Black, Almond, Bronze Antique, Brushed Nickel, Chrome		White, Brown, Gray, Black, Almond	White, Brown, Gray, Black, Almond, Bronze Antique, Brushed Nickel, Chrome		White, Brown, Gray, Black, Almond		
<b>Shade Motor</b>										
CSM-QMTDC-163-1-EX/CN		✓		✓				✓		
CSM-QMTDC-163-1-SG					✓	✓				
CSM-QMTDC-250-1-EX/CN	✓		✓				✓		✓	✓
CSM-QMTDC-275-1-EX/CN	✓		✓						✓	✓
<b>System Width</b>										
Minimum	18 in. (458 mm)	17.5 in. (445 mm)	18 in. (458 mm)	17.5 in. (445 mm)	24 in. (610 mm)	22 in. (559 mm)	18 in. (458 mm)	17.5 in. (445 mm)	18 in. (458 mm)	18 in. (458 mm)
					29 in. (737 mm) with blackout channels					
Maximum Bracket-to-Bracket (B2B) Width	168 in. (4,268 mm)	96 in. (2,439 mm)	133 in. (3,379 mm)	96 in. (2,439 mm)	96 in. (2,439 mm)	96 in. (2,439 mm)	120 in. (3,048 mm)	96 in. (2,439 mm)	120 in. (3,048 mm)	120 in. (3,048 mm)
<b>Mounting Bracket Features</b>										
Ceiling, Wall, or Jamb Mount	✓	✓	✓	✓	✓	✓	✓	✓	✓	✓



	CS-SHADE-ROLLER				CS-SHADE-ROLLER-BATT		CS-SHADE-ROMAN	CS-SHADE-ROLLER-HSHEER	CS-SHADE-ROLLER-CABLEGUIDED	
Compatible Bracket:	CSA-ARCH5	CSA-ARCH3	CSA-DECOR5	CSA-DECOR3	CSA-ARCH3	CSA-DECOR3	CSA-DECOR5	CSA-ARCH3	CSA-ARCH5	CSA-DECOR5
3-Axis Adjustment	✓	✓						✓	✓	
2-Axis Adjustment			✓	✓	✓	✓	✓			✓
<b>Power</b>										
24VDC	✓	✓	✓	✓			✓	✓	✓	✓
Battery					✓	✓				
<b>Communications</b>										
Cresnet® Wired	✓	✓	✓	✓			✓	✓	✓	✓
infiNET EX® Wireles	✓	✓	✓	✓			✓	✓	✓	✓
SG Wireless					✓	✓				
<b>Non-Motorized</b>	✓	✓	✓	✓				✓		

\* Bronze antique, brushed nickel, and chrome not available for non-motorized shades

# Digital QMT Roller Shade Motors

Crestron offers a variety of Digital QMT® shade motors providing quiet, yet robust operation for Crestron roller shades. All Crestron QMT shade motors are available using Crestron's reliable Cresnet wired communication and SG and infiNET EX wireless communication.

Digital QMT shade motor features:

- Long-life brushless motor featuring Digital Quiet Motor Technology™ for nearly inaudible operation
- Real-time activity monitoring and status feedback
- Local pushbutton interface for testing shades and setting shade limits
- Local diagnostic LEDs to indicate shade status
- Smooth starts and stops with programmable stop points
- Reactive features that detect and react to obstructions in the shade path to avoid motor damage
- Limited Lifetime Warranty

## 3/4 Nm Motors

### CSM-QMTDC-163 Series Shade Motors

- 3/4 Nm torque.
- Used with the 1.625 in. (42 mm) shade tube.
- Available with built-in infiNET EX (-EX models), SG (-SG models), or Cresnet (-CN models) communications.
- Available models:
  - [CSM-QMTDC-163-1-CN](#)
  - [CSM-QMTDC-163-1-EX](#)
  - [CSMI-QMTDC-163-1-EX](#)
  - [CSM-QMTDC-163-1-SG](#)
  - [CSMI-QMTDC-163-1-SG](#)



## 4 Nm Motors

### CSM-QMTDC-250-4 Series Shade Motors

- 4 Nm torque.
- Used with the 2.50 in. (64 mm) shade tube.
- Available with built-in infiNET EX (-EX models) or Cresnet (-CN models) communications.
- Available models:
  - [CSM-QMTDC-250-4-CN](#)
  - [CSM-QMTDC-250-4-EX](#)
  - [CSMI-QMTDC-250-4-EX](#)



### CSM-QMTDC-275 Series Shade Motors

- 4 Nm torque.
- Used with the 2.75 in. (70 mm) shade tube.
- Available with built-in infiNET EX (-EX models) or Cresnet (-CN models) communications.
- Available models:
  - [CSM-QMTDC-275-4-CN](#)
  - [CSM-QMTDC-275-4-EX](#)
  - [CSMI-QMTDC-275-4-EX](#)



## Manual Clutch

Keep the same look and feel on all your windows even if they are not all motorized. Many of Crestron's roller shade solutions are available with manual clutch operation using a bead-chain to raise and lower the shade fabric. Manually operated shades are a cost-effective alternative to motorized shades.

A manual-to-motorized upgrade kit is available which allows any single-roll manual clutch shade to be easily converted to motorized operation.

# Roller Shade Mounting Brackets

Crestron offers variety of Architectural and Décor roller shade mounting brackets to fit virtually all mounting scenarios. The mounting brackets can be mounted on a wall, on a ceiling, in a pocket, or on a window jamb.



## QMT3 Series Architectural Brackets

QMT3 Series Architectural hardware from Crestron is a small mounting system. The hardware offers solutions for both single and dual roll shade applications.

### CSA-ARCH3-BRKT

- The [CSA-ARCH3-BRKT](#) supports a single Crestron roller shade.
- Motorized shade operation is provided by the Crestron CSM-QMTDC-163-1 Digital QMT motor.
- Brackets are left-right and up-down adjustable to ensure mounting precision and to shorten installation time by allowing the installer to make changes without removing and reinstalling the entire bracket.
- Compatible with CS-SHADE-ROLLER, CS-SHADE-ROLLER-BATT, and CS-SHADE-ROLLER-HSHEER shade systems

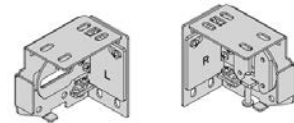

## CSA-ARCH3-BRKT-DUAL

- The [CSA-ARCH3-BRKT-DUAL](#) supports two Crestron roller shades in a compact space.
- Motorized shade operation is provided by the Crestron CSM-QMTDC-163-1 Series Digital QMT motor.
- Brackets are left-right and up-down adjustable to ensure mounting precision and to shorten installation time by allowing the installer to make changes without removing and reinstalling the entire bracket.
- Compatible with CS-SHADE-ROLLER shade systems

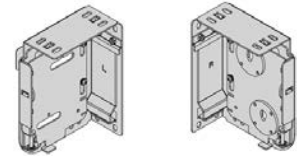

## QMT5 Series Architectural Brackets

QMT5 Series Architectural Shade Hardware from Crestron is a mounting system that allows Crestron shades to be mounted on a wall or ceiling, or in a pocket or window jamb. The hardware offers solutions for both single roll and dual roll shade applications.

### CSA-ARCH5-BRKT

- The [CSA-ARCH5-BRKT](#) supports a single Crestron roller shade.
- Motorized shade operation is provided by the Crestron CSM-QMTDC-250-4 or CSM-QMTDC-275-4 Series Digital QMT motor.
- Brackets are left-right and up-down adjustable to ensure mounting precision and to shorten installation time by allowing the installer to make changes without removing and reinstalling the entire bracket.
- Compatible with CS-SHADE-ROLLER and CS-SHADE-ROLLER-HSHEER shade systems



### CSA-ARCH5-BRKT-DUAL

- The [CSA-ARCH5-BRKT-DUAL](#) supports two Crestron roller shades.
- Motorized shade operation is provided by the Crestron CSM-QMTDC-250-4 or CSM-QMTDC-275-4 Series Digital QMT motor.
- Brackets are left-right and up-down adjustable to ensure mounting precision and to shorten installation time by allowing the installer to make changes without removing and reinstalling the entire bracket.
- Compatible with CS-SHADE-ROLLER shade systems

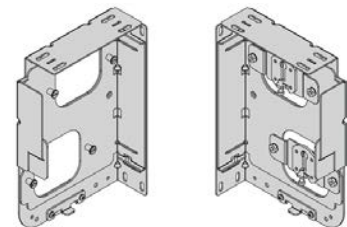

## CSA-ARCH5-BRKT-CPLR-ANG

- The [CSA-ARCH5-BRKT-CPLR-ANG](#) supports a single Crestron roller shade.
- Couple up to six roller shades (depends on shade width and fabric selection).
- Conforms to virtually any angled wall or window configuration.
- Compatible with CS-SHADE-ROLLER shade systems

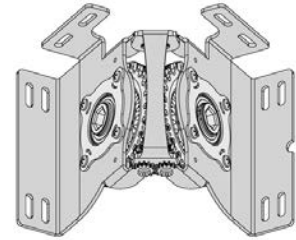

## CSA-ARCH5-BRKT-CPLR

- The [CSA-ARCH5-BRKT-CPLR](#) supports a single Crestron roller shade.
- Couple up to six roller shades (depends on shade width and fabric selection).
- Compatible with CS-SHADE-ROLLER shade systems

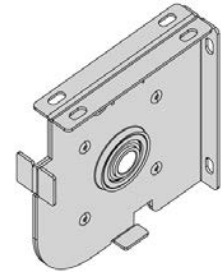

## CSA-ARCH5-BRKT-DUAL-CPLR

- The [CSA-ARCH5-BRKT-DUAL-CPLR](#) supports dual Crestron roller shades.
- Couple two groups of up to six roller shades (depends on shade width and fabric selection).
- Compatible with CS-SHADE-ROLLER shade systems

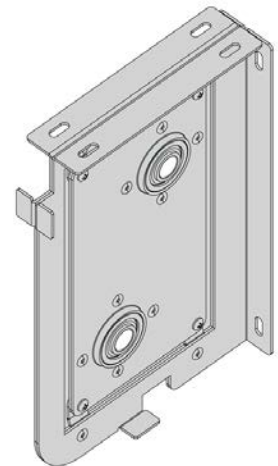

## QMT3 Series Décor Brackets

QMT3 Series Décor hardware from Crestron is a small mounting system that allows a Crestron shade to be mounted on a wall, ceiling, or window jamb where the entire shade will be exposed, giving the space a contemporary look.

### CSA-DECOR3-BRKT

- The [CSA-DECOR3-BRKT](#) supports a single Crestron roller shade.
- Motorized shade operation is provided by the Crestron CSM-QMTDC-163-1 Series Digital QMT motor.
- Brackets are left-right and up-down adjustable to ensure mounting precision and to shorten installation time by allowing the installer to make changes without removing and reinstalling the entire bracket.
- Compatible with CS-SHADE-ROLLER and CS-SHADE-ROLLER-BATT shade systems

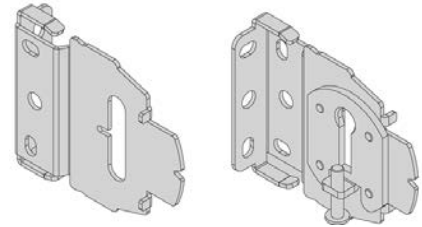

## QMT5 Series Décor Brackets

QMT5 Series Décor hardware from Crestron is a stylish mounting system that allows a Crestron shade to be mounted on a wall, ceiling, or window jamb where the entire shade will be exposed, giving the space a contemporary look.



## CSA-DECOR5-BRKT

- The [CSA-DECOR5-BRKT](#) supports a single Crestron roller shade.
- Motorized shade operation is provided by the Crestron CSM-QMTDC-250-4 Series Digital QMT motor.
- Brackets are left-right and up-down adjustable to ensure mounting precision and to shorten installation time by allowing the installer to make changes without removing and reinstalling the entire bracket.
- Compatible with CS-SHADE-ROLLER, CS-SHADE-ROMAN, and CS-SHADE-ROLLER-CABLEGUIDED shade systems

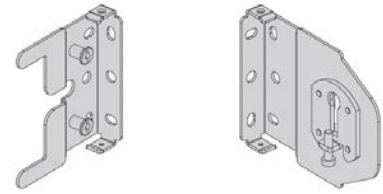

## CSA-DECOR5-BRKT-CPLR

- The [CSA-DECOR5-BRKT-CPLR](#) supports a single Crestron roller shade.
- Couple up to six roller shades (depends on shade width and fabric selection).
- Compatible with CS-SHADE-ROLLER shade systems





# Roller Shade Tube Options

Crestron offers several shade tube options to accommodate a wide array of roller shade widths and shade fabric weights. When multiple shade tube sizes are used in the area, all roller shades can be upgraded to the larger tube size to keep a similar aesthetic across the shades.

- The QMT3 Series Architectural and Décor hardware utilize a 1.625 in. shade tube to support the shade fabric.
- The QMT5 Series Architectural and Décor hardware utilize a 2.50 in. or 2.75 in. shade tube to support the shade fabric. The 2.75 in. shade tube allows heavier fabric to be used and reduce the amount of deflection in the system.
- The QMT5 Series Architectural and QMT5 Series Décor hardware when used with couplers uses the 2.50 in. shade tube.
- Roman shades utilize a 2.50 in. shade tube to support the shade fabric.

# Roller Shade Mounting Options

There are three different mounting options available for each mounting bracket.

## Inside Mount

The mounting brackets are installed within the window frame. They can be mounted to the jamb or the header.

Shade accessories such as fascia, top/back cover, and end caps may be used to conceal the mounting hardware.



## Outside Mount

The mounting brackets are installed outside of the window frame. They can be mounted to the wall or the ceiling.

Shade accessories such as fascia, top/back cover, and end caps may be used to conceal the mounting hardware.



## Pocket Mount

The mounting brackets can be installed inside of a pocket to conceal the entire shade assembly. A prefabricated pocket may be purchased from Crestron, or a pocket may be custom built to fit the mounting brackets. The prefabricated pocket can be installed using either the inside mount or outside mount method.

**NOTE:** Battery-powered shades (CS-SHADE-ROLLER-BATT) are not compatible with pocket mount installations.



# Roller Shade Accessories

A variety of accessories are available to make sure that the shades are perfectly installed.

**NOTE:** Accessories are not compatible with all shade systems and all configurations. For details, refer to CDT and [Crestron Roller Shade Options \(on page 9\)](#).

## Blackout Accessories

Crestron offers blackout accessories to eliminate light leaking around the edges of fabrics. Blackout accessories are typically used with Architectural style hardware and can be ordered with each shade or independently.

### Side Channel



The Side Channel (CSA-ARCH-BO-CHANNEL-U) is used on the sides of shades for blackout applications. The Side Channel comes in 2-1/2 in. (64 mm) and 1-1/2 in. (38 mm) widths. The mounting surface of the Side Channel has a grooved line for easy drilling. The opposite side of the Side Channel is smooth.

### H-Channel



The H-channel (CSA-ARCH-BO-CHANNEL-H) is used between two shades for blackout applications. The H-channel is 5 in. (127 mm) wide. The mounting surface of the H-channel has grooved lines for easy drilling and for reducing the need for a center punch. The opposite side of the H-channel is smooth. Plugs are available to conceal holes in the channel. Use a 3/8 in. drill bit for the plugs.

### Sill Angle

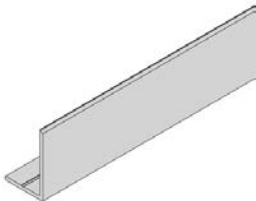

The sill angle (CSA-ARCH-BO-SILL) is used for blackout applications by preventing light leaks along the bottom of the shade. The sill angle is used in conjunction with a blackout hem bar. The side of the sill angle contains a grooved line for easy drilling and for reducing the need for a center punch.

## Liner (Wool Pile)

Liner comes in two sizes and is available in black and white. Small liner is installed in Side or H-channels and large liner is optionally installed in pocket. Liner is used to enhance the light block characteristics of these accessories and is preinstalled when side channel or pockets are ordered with a shade.

## Channel Cap

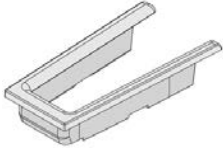

H-channels and Side Channels come with caps (CSA-ARCH-BO-CHANNEL-CAP) to provide a clean finish on the cut ends. The channel caps can fit the 2-1/2 in. (64 mm) or 1-1/2 in. (38 mm) channel widths. The channel caps press into place. Four channel caps come with the H-channel; two channel caps come with the Side Channel.

## Fascia Options

The fascia is used to conceal the front and bottom of the shade bracket. The lip on the bottom of the fascia also helps conceal the shade roller tube. The fascia snaps onto the tabs of the mounting bracket.

The fascia is available square or round and is designed to fit single brackets (CSA-ARCH5-BRKT) and dual brackets (CSA-ARCH5-BRKT-DUAL). A smaller square fascia is designed for manual shades (CSA-ARCH5-BRKT-MAN).

### Square Fascia

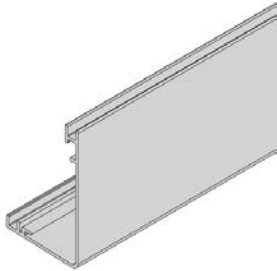

For battery-operated shades, the battery pack is integrated into the fascia. The integrated battery pack provides access to the batteries for fast and easy installation and replacement.

### Round Fascia for Battery-Powered Shades

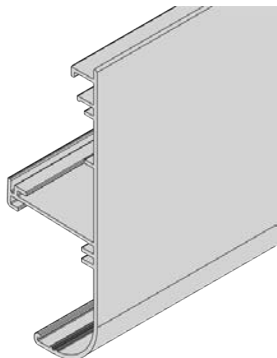

## End Cap Options

Decorative end caps help visible shade brackets blend into the room.

### Decor End Caps

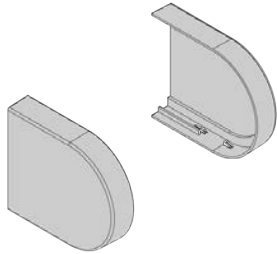

Decorative end caps are placed over the mounting brackets to conceal mounting hardware. End caps are provided in a variety of colors.

### Architectural End Caps

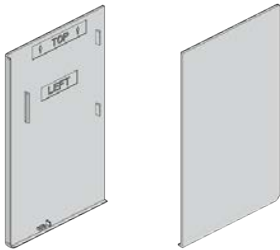

Architectural end caps conceal the end of the bracket when the sides are exposed. The end caps can be used with square or curved fascia and the top and back cover. The end caps are available square or round and are designed to fit single brackets (CSA-ARCH5-BRKT) and dual brackets (CSA-ARCH5-BRKT-DUAL).

## Top and Back Cover

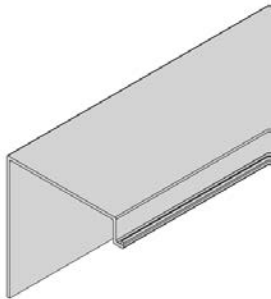

The top and back cover allow the Architectural shade hardware to be concealed when the shade is viewed from above and when the shade can be viewed from outside the window. Top and back covers are available for single Architectural brackets (CSA-ARCH3-TBC and CSA-ARCH5-TBC) and dual Architectural brackets (CSA-ARCH5-TBC-DUAL).



## Pocket

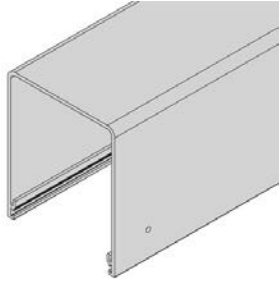

Prefabricated pockets reduce the need for custom framing for the shade and allow an easy installation. A single pocket (CSA-ARCH5-POCKET and CSA-ARCH3-POCKET) and a dual pocket (CSA-ARCH3-POCKET-DUAL) are available for installations where the pocket cannot be built into the window frame (retrofit applications). The inside of the pocket contains grooved lines for easy drilling and for reducing the need for a center punch.

Pockets are available with a tile lip that supports the edge of a ceiling tile.

## Flap

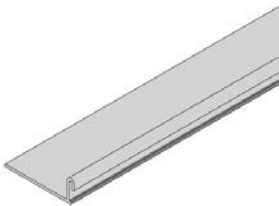

The flap (CSA-ARCH5-FLAP) is an accessory that attaches to the inside of the pocket from the room or window side of the pocket. It blocks the opening at the bottom of the pocket so that the shade and hardware cannot be seen. The flap can also attach to a hanger.

## Hanger

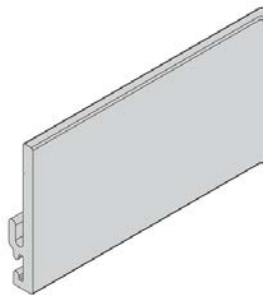

Hangers are designed to mount to the edge of a custom fabricated pocket to hold a pocket flap. The hanger should be mounted inside the pocket. The hanger with a tile lip is used where there is a drop ceiling. The side of the hanger contains a grooved line for easy drilling and for reducing the need for a center punch.

## Hanger with Tile Lip

The pocket flap hanger with tile lip is designed to mount to the edge of a custom fabricated pocket to hold a pocket flap. It also has a lip to support ceiling tiles. The side of the hanger contains a grooved line for easy drilling and for reducing the need for a center punch.

## Pocket End Cap

Metal pocket end caps are available for use with pockets and provide a finished look in an exposed application or provide a complete shade enclosure in a recessed application.

# Roller Shade Fabrics and Textiles

Crestron offers a variety of fabric colors with an array of fabric properties that suit every space and budget. Crestron offers shade fabrics that are certified environmentally safe, recyclable and eco-friendly, mold- and bacteria-resistant, PVC-free, lead-free, and fire-retardant.

## Fabric Characteristics

Crestron offers fabric in transparent, translucent, and blackout.

### Transparent



Transparent fabrics transmit light so that objects or images are seen through the weave of the fabric. These have an openness factor between 3-10%.

Benefits:

- Solar protection
- Natural light and glare control
- Reduced solar heat gain

### Translucent



Translucent fabrics transmit diffused light and enhance privacy. The exterior view is only partially visible as silhouettes and shadows. These fabrics typically have an openness factor between 0-1%.

Benefits:

- Solar protection
- Privacy
- Enhanced natural light filtration
- Reduced solar heat gain

### Blackout



Blackout fabrics provide advanced light blockage and privacy. Use additional accessories to create a complete blackout solution and prevent light leaks along the window jambs and sill.

Benefits:

- Ultimate light and glare control
- Complete privacy
- Dramatic reduction in solar heat gain

## Fenestration Data

Fenestration data is used by designers to assist them when choosing a fabric. Fenestration data includes the following:

- **Solar Transmittance (Ts):** The ratio of total solar energy that contacts the shade fabric and is allowed through the fabric and into the space.
- **Solar Reflectance (Rs):** The ratio of total solar energy that contacts the shade fabric and is reflected away from the space.
- **Solar Absorbance (As):** The ratio of total solar energy that contacts the shade fabric and is absorbed into the shade fabric.

**NOTE:** The sum of Ts, Rs, and As will always be 100.

- **Visible Transmittance (Tv):** The ratio of total solar energy that is allowed to pass through the shade fabric. The value is the amount of glare that is seen through the shade fabric. For example, a Tv value of 2% indicates that 98% of glare is reduced.
- **Openness Factor (OF):** The OF is the percentage of open space in the fabric. The percentage determines how much light, heat, and glare the fabric allows to enter. A high OF factor lets in more light than a lower OF factor. UV blocking shades do not provide privacy at night.

## Hem Bar Styles

The hem bar on a Crestron roller shade provides weight at the bottom of the fabric so that the fabric hangs straight and travels up and down smoothly on the tube. Hem bars are available in three different styles: Open Pocket, Sealed Pocket, and Exposed Blackout.

### Open Pocket Hem Bar

The open pocket hem bar is an appropriate choice for when the designer does not want to add any additional detail to the bottom of the drawn shade. The pocket has an opening on each end providing a simple finish to the shade. The hem bar is taped to the fabric inside of the pocket to prevent the hem bar from moving.

Optional end caps may be ordered for an elegant finish to an open pocket.



### Sealed Pocket Hem Bar

The sealed pocket hem bar is intended for use with single-sided seamable fabrics. The sealed pockets enclose the weighted hem bar making them ideal for schools and homes with small children. However, the pinched end is less desirable with designers.



## Exposed Blackout Hem Bar

The exposed blackout hem bar is intended for use in blackout applications. The hem bar blocks light from leaking in through the bottom of the roller shade fabric. The exposed blackout hem bar is available in almond, black, brown, gray, and white.



## Fabric Railroading

When the desired roller shade width is larger than the shade fabric width, railroading the shade fabric is an option to meet the desired shade width. Railroading the shade fabric rotates the shade fabric, and any associated pattern in the shade fabric, 90 degrees.

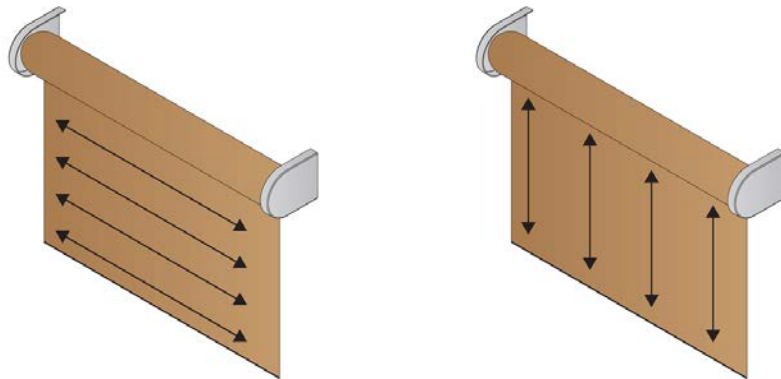

## Seams

If the shade fabric is railroaded and the window height is larger than the width of the fabric, multiple pieces of fabric must be connected which creates a seam in the shade fabric.

When placing multiple roller shades in the same room, if one shade needs to be railroaded with a seam all other shades should be railroaded. This creates a consistent view amongst the shades in the room. Seams can be specified for non-railroaded shades in the same room at no extra cost.

When possible, align seams with window hardware or a mullion.

Vertical seams are not allowed on roller shades because they create an uneven roll on the tube, causing telescoping or tracking. Telescoping occurs when the fabric shifts excessively to the left or right of the roller tube as the shade is being rolled up.

## Batten

When shade fabrics are very tall or very wide, the shade fabric may curl along the edges. To provide stability for the shade or to prevent edge curling, battens may be sealed into the fabric.

When possible, align battens with window hardware or a mullion.

Battens are typically spaced evenly throughout the length of the shade fabric. Custom batten location requests can be made to position battens to suit the window architecture. When using side channels on large shades, battens can be used to minimize fabric edge curling.

# Specialty Roller Shades

Crestron also offers Battery Powered roller shades, Horizontal sheers, Roman Shade kits and Cable Guided roller shades.

## Battery-Powered Shades

Crestron battery-powered shades ([CS-SHADE-ROLLER-BATT](#)) add beauty, convenience, and comfort to any interior space. Install battery-powered shades in locations where power and control wires cannot be run. A battery pack powers the shade motor while the SG radio provides control and status of the shade.

- Easy installation in post-construction or retrofit applications
- 3 year (average) battery life
- Install shades where power and control cabling cannot be run
- Designed for use with Crestron® QMT®3 Series Architectural or QMT3 Series Décor shade hardware
- For roller shades 22 to 96 in. (559 to 2,439 mm) wide using Décor shade hardware
- For roller shades 24 to 96 in. (610 to 2,439 mm) wide using Architectural shade hardware
- Fully integrated antenna— no external antenna or dongle required
- Control system integration using SG wireless communications
- Powered using 8 D cell batteries in an external battery pack



## Crestron Horizontal Sheers

The Crestron Horizontal Sheers ([CS-SHADE-ROLLER-HSHEER](#)) add beauty, convenience, and comfort to any interior space. Horizontal fabric vanes float between two layers of sheer, knitted fabric. The horizontal sheer can be raised for an unobstructed view and lowered to soften the view. When the horizontal sheer is lowered, the vanes can be tilted to increase the natural light levels or to provide privacy.

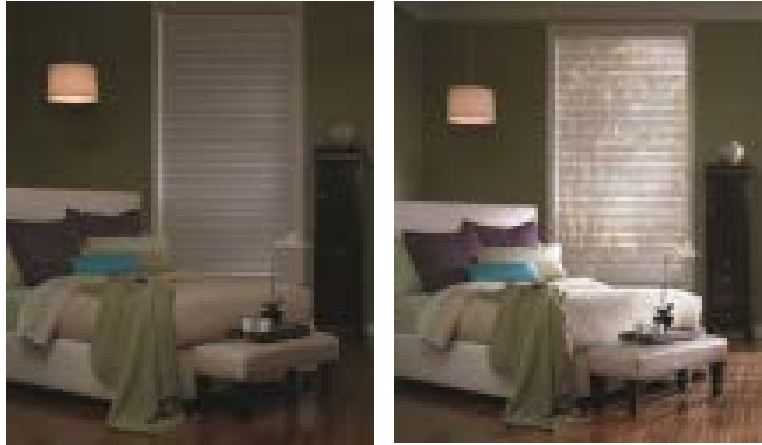

- Horizontal sheers are available for windows up to 8 ft x 8 ft (2.4 m x 2.4 m).
- Vane fabrics are available in 36 decorative colors and patterns with a choice of 25 light filtering and 11 room darkening options.
- The large 2.5 in. (64 mm) vanes provide ~1.25 in. (~32 mm) view-through when tilted open.
- Universal mounting brackets allow inside mount within a window jamb or outside mount to the window casing, wall, or ceiling surface.
- Decorative curved front fascia with matching fabric insert. Available with top and back cover.

## Roman Shades



Roman shades use a variety of fabric folds, such as flat, cascade, relaxed, or pleated, to provide an elegant look to the space.

Roman shades give windows the softness and style of draperies, but with less bulk.

Similar to other Crestron roller shades, roman shades can be used as aesthetically as the focal point of the room or functionally to block out sunlight.

Crestron offers Roman Shade kits that use QMT5 Series Décor shade hardware (CSS-DECOR5). Provide the Roman Shade kit to a local workroom to create a Roman shade that is powered by Crestron and created by you.



## Cable Guided Shades

The Crestron Cable Guided Shades ([CS-SHADE-ROLLER-CABLEGUIDED](#)) use Crestron QMT5 Series Architectural and Décor shade hardware (CSS-ARCH5 and CSS-DECOR5) mounting hardware and a set of cables to guide roller shades on an angle.

As part of a complete engineered shading solution, it provides a cable-guided tracking solution to prevent the shade fabric from swaying and allows for installation on angled windows.

It is compatible with inside, outside, and pocket mounted roller shades up to 10 ft (3 m) wide or 10 ft (3 m) long when using the 2.50 in. tube, and 13 ft (4 m) or 10 ft (3 m) long when using the 2.75 in. tube. Cable guided shade assemblies accommodate windows pitched inwardly or outwardly at up to 20 degrees from vertical.

The cable-guided option employs a pair of tensioned steel cables running vertically at either side of the shade fabric. A specially weighted hem bar with slotted end caps glides up and down the cables as the shade is raised and lowered. Small decorative anchors attach the cables at the bottom to the windowsill, window jamb, or floor. Precision brackets or blocks mount at the top to the window header, window jamb, or ceiling. Adjustable cable fittings allow for proper tensioning of each cable to ensure smooth travel and minimal sag.



**NOTE:** The shade fabric does not retract fully when raised. At its upper limit, the hembar and some amount of fabric remains visible. Not compatible with blackout options. A minimum 1-1/4 in. (32 mm) light gap is expected.

# Roller Shade Measuring Guidelines

Take the measurements for roller shades after the window is fully finished, this allows window casing, mounting pocket, window sill, window hardware, and other obstructions to be taken into consideration. Log shade measurements as width by height.

## How to Measure Single Roller and In-Line Coupled Roller Shades

Use the [Shade Measuring Worksheet - Single Roller and In-Line Coupled Shades](#) (PDF) (Doc. 7925) for additional information when measuring shades, to log the measurements, and to submit the measurements.

When measuring for single roller or in-line coupled shade, note the following:

- Inspect the window and the area around the window for window hardware (knobs, sills, etc.) that may prevent the smooth travel of the shade.
- Verify that the window frame, window sill, and the window header are level, and then measure all designations.
- Measure the location where the brackets will be mounted.
- Measure the shade height and width in three different locations. Log the smallest value.
- For outside mount shades, measure the bracket-to-bracket (B2B) width (1) or the fabric width (3) and the shade height (2).
- For inside mount shades, measure the bracket-to-bracket (B2B) width (4), shade height (6), and depth (5)
- When placing an order for an inside mount shade in CDT, the user will be asked if Crestron should adjust the bracket-to-bracket measurement. If Yes is selected, an 1/8 in. deduction will be made on all roller shades that were specified as inside mount.

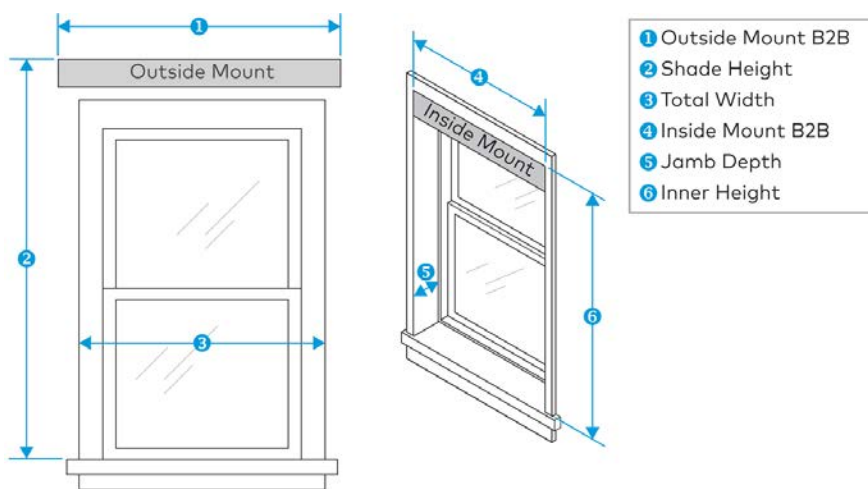

# How to Measure Angled Coupled Shades

Use the [Shading Solutions Measuring Worksheet - Angle Coupled Shades](#) (PDF) (Doc. 7925) for additional information when measuring shades, to log the measurements, and to submit the measurements.

When measuring for an angled coupled shade, note the following:

- Check that all window frames are level and plumb with each other.
- Check that the surface is flat before measuring angles.
- Inspect the window and the area around the window for window hardware (knobs, sills, etc.) that may prevent the smooth travel of the shade.
- Measure the location where the brackets will be mounted.
- Measure the shade height and width in three different locations. Log the smallest value.
- If the brackets are not installed, measure the shade width (B-1, B-2, B-3, etc), the inside angles ( $\theta$ -1,  $\theta$ -2, etc.), and the shade height (A).
- If the brackets are installed, measure the bracket-to-bracket width (B2B-1, B2B-2, B2B-3, etc). Measure to the outside of the brackets.
- Angled coupled shades are not configurable with any top treatments (fascia, pocket, etc.). A custom-built pocket is suggested to have a (5 in. depth x 6 in. height) minimum inside dimension for the custom pocket.

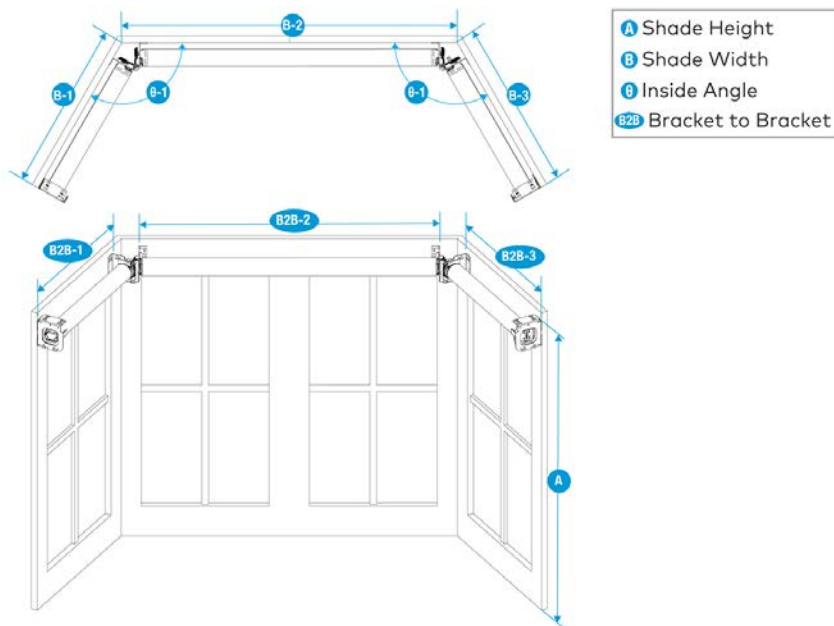

# Installation Dimensions

## QMT3 Series Architectural Brackets

CSA-ARCH3-BRKT

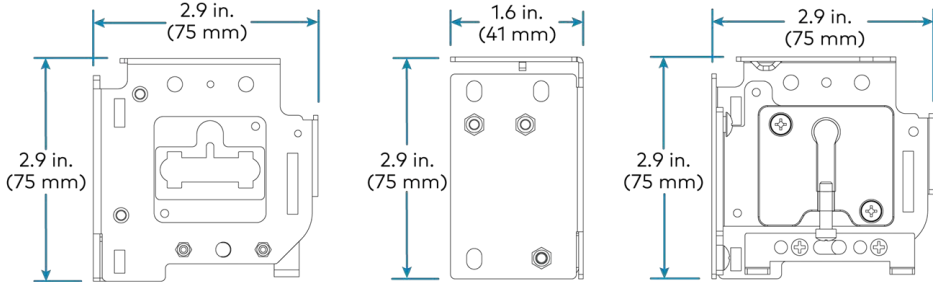

CSA-ARCH3-BRKT in a Blackout Configuration

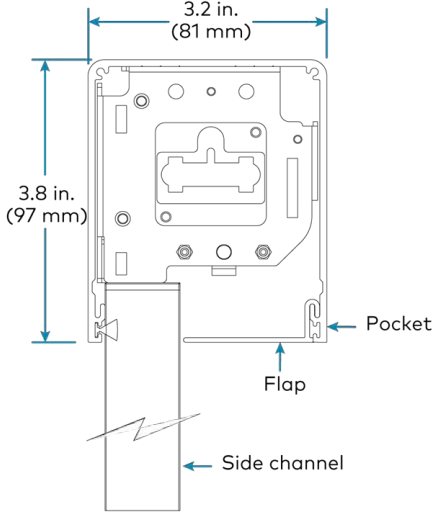

**CSA-ARCH3-BRKT Bracket for CS-SHADE-ROLLER-BATT**

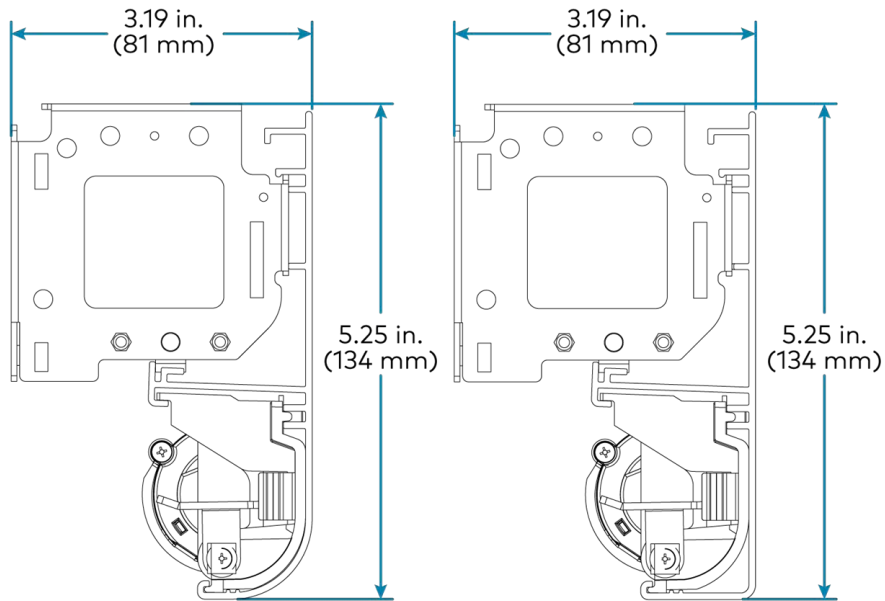

**CSA-ARCH3-BRKT-DUAL**

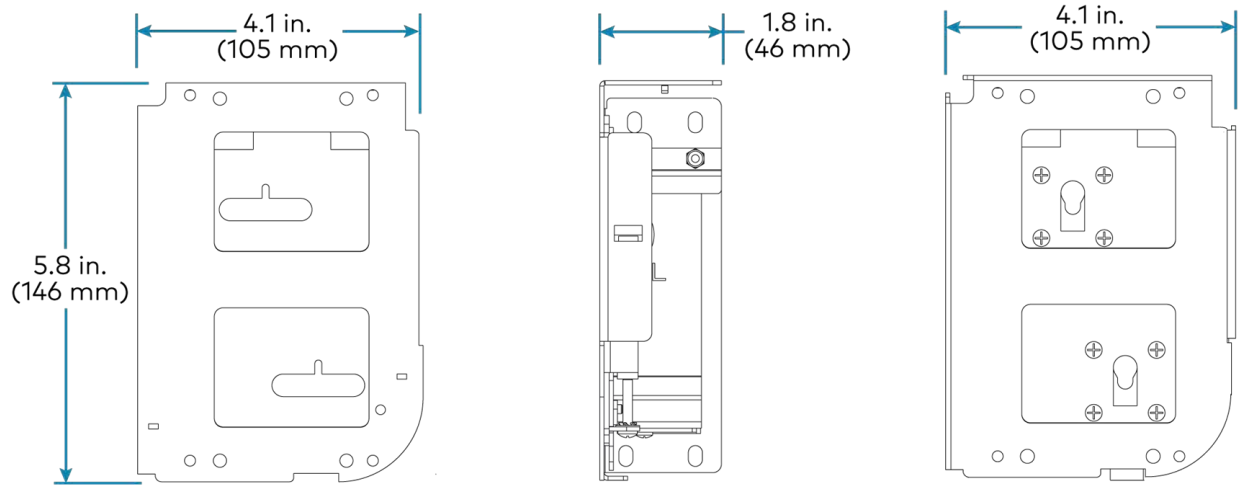

**CSA-ARCH3-BRKT-DUAL with Square Fascia and Top and Back Cover**

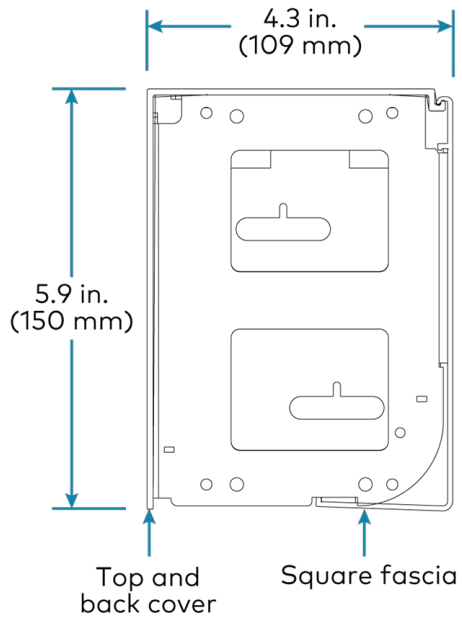

**CSA-ARCH3-BRKT-DUAL with Curved Fascia and Top and Back Cover**

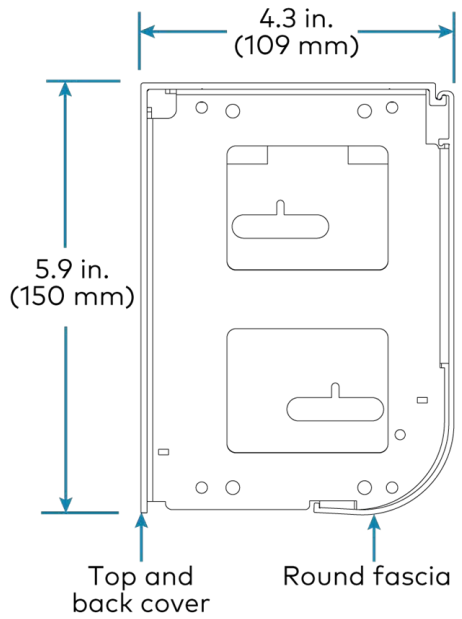

**QMT3 Series Dual Architectural Pocket with Flap, Hanger, and Tile Lip**

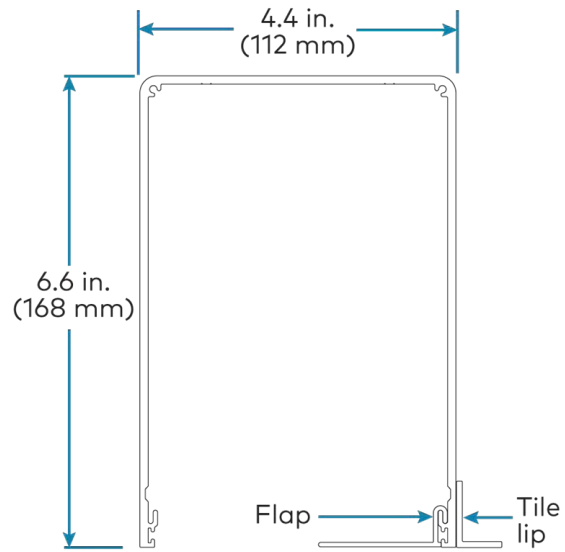

**CSA-ARCH3-BRKT-DUAL in a Blackout Configuration**

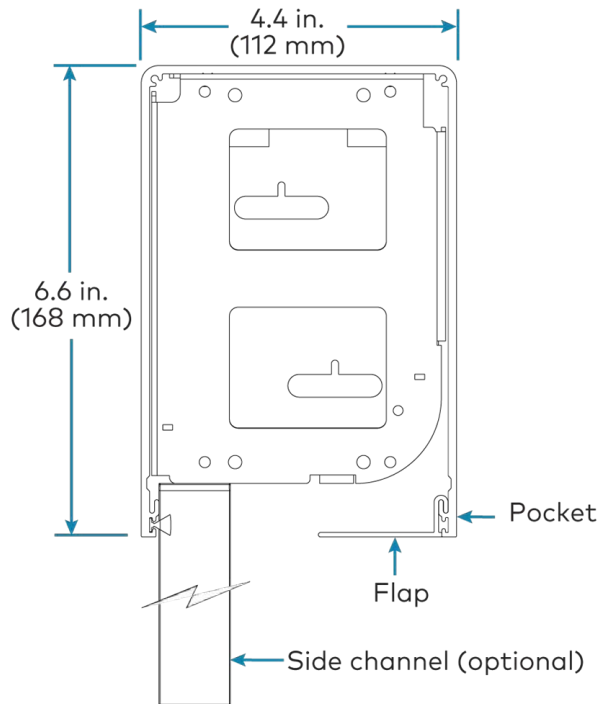

# QMT5 Series Architectural Brackets

## CSA-ARCH5-BRKT

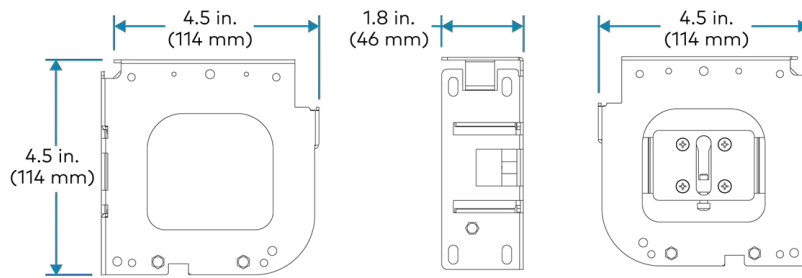

## QMT5 Series Architectural Pocket with Flap, Hanger, and Tile Lip

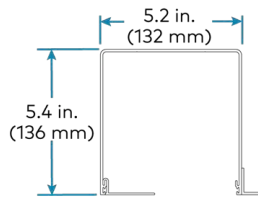

## CSA-ARCH5-BRKT with Square and Curved Fascia and Top and Back Cover

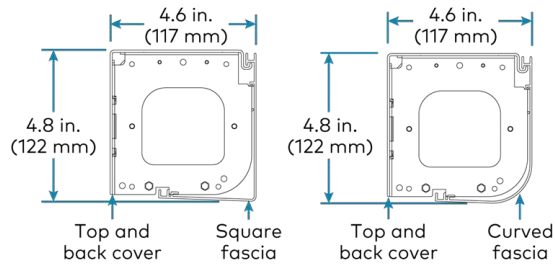

## CSA-ARCH5-BRKT in a Blackout Configuration

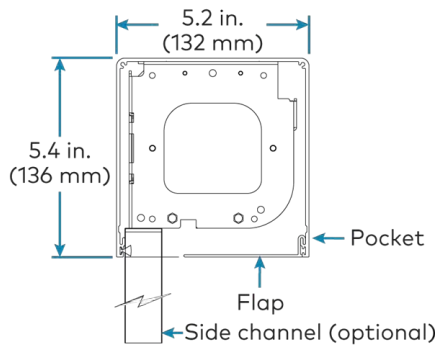



**CSA-ARCH5-BRKT-DUAL**

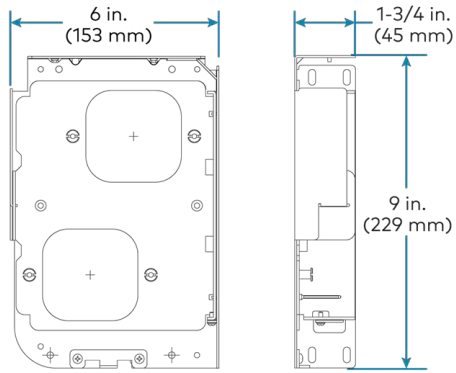

**CSA-ARCH5-BRKT-DUAL with Square and Curved Fascia and**

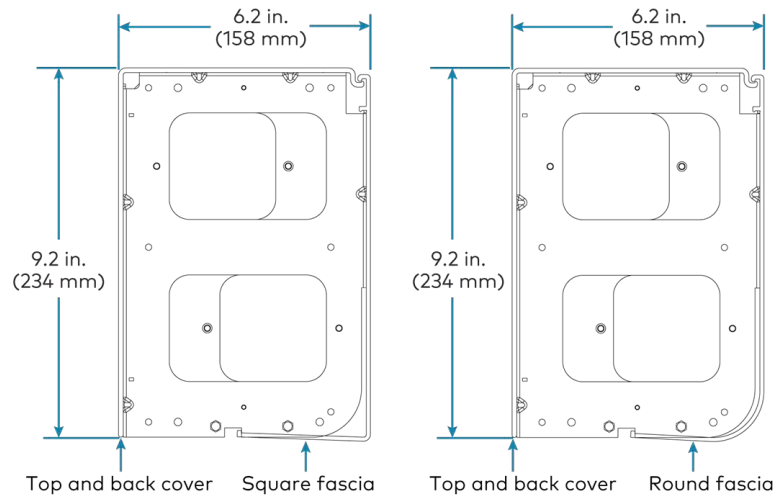

**CSA-ARCH5-BRKT-CPLR-ANG**

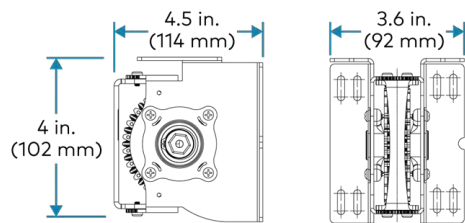

**CSA-ARCH5-BRKT-CPLR**

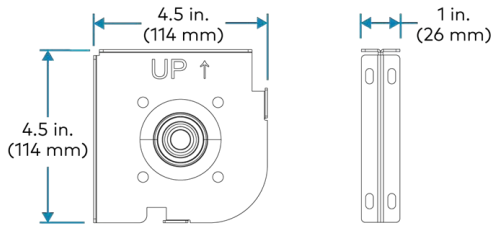

**CSA-ARCH5-BRKT-DUAL-CPLR**

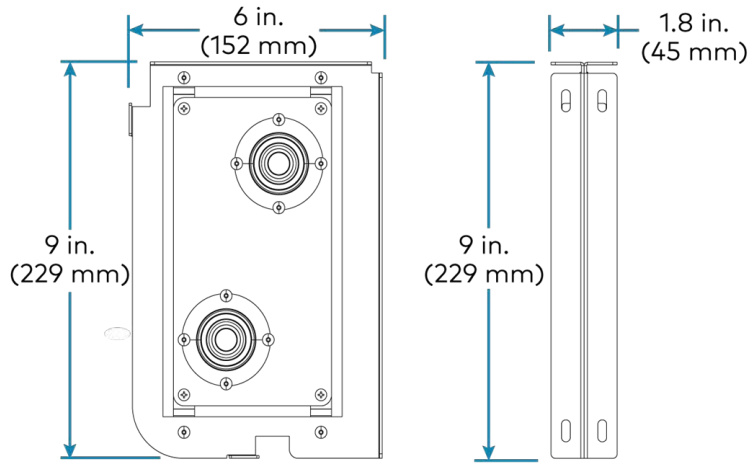

## QMT3 Series Décor Bracket

**CSA-DECOR3-BRKT**

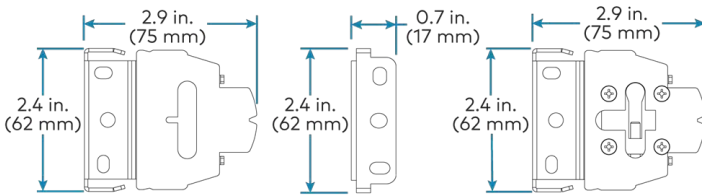

# QMT5 Series Décor Brackets

## CSA-DECOR5-BRKT

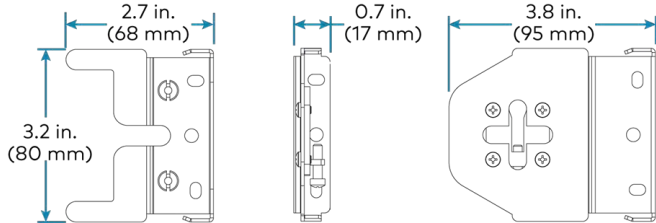

## CSA-DECOR5-BRKT-CPLR

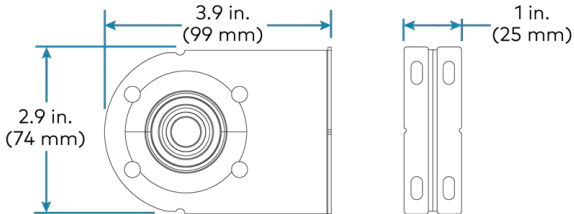

# Creating Custom Pockets for QMT3 Series Architectural Brackets

CSA-ARCH3-BRKT in a Custom Pocket

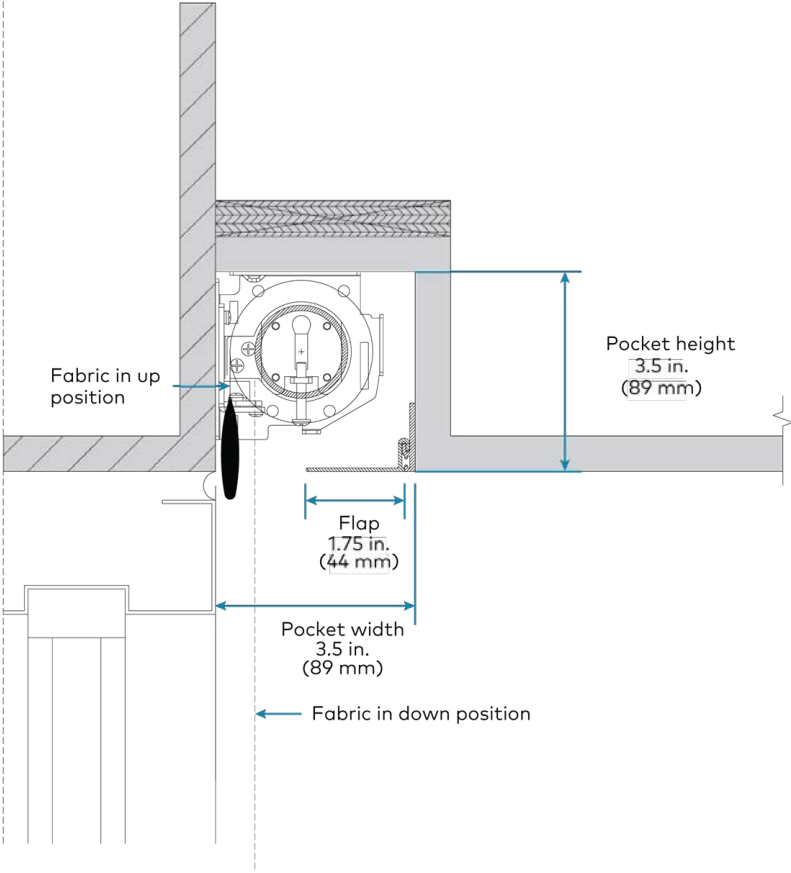

CSA-ARCH3-BRKT-DUAL in a Custom Pocket

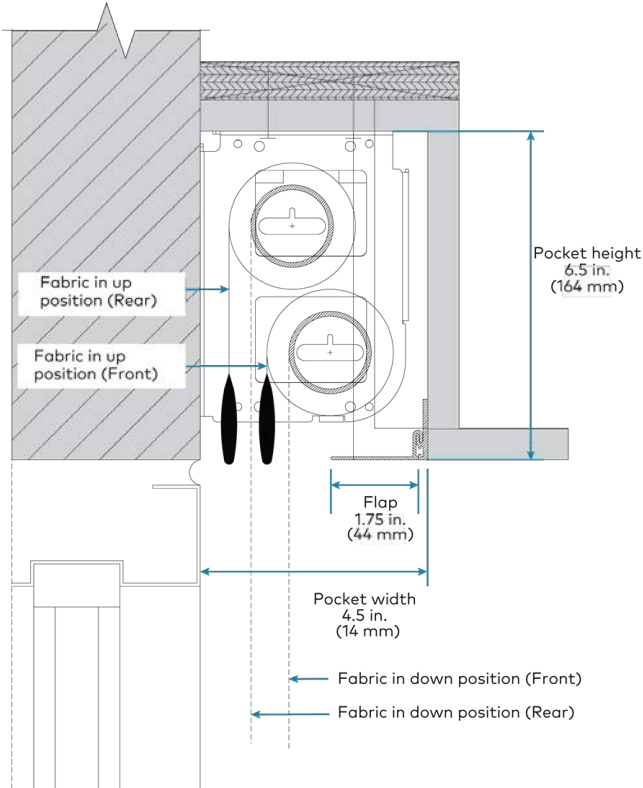

# Creating Custom Pockets for QMT5 Series Architectural Brackets

CSA-ARCH5-BRKT in a Custom Pocket

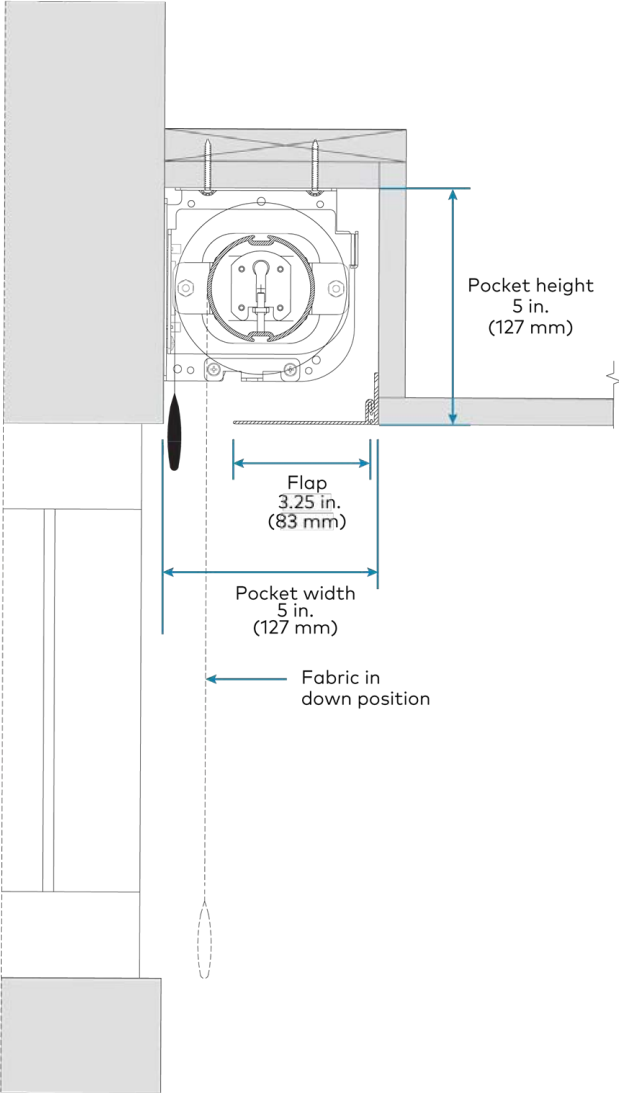

CSA-ARCH5-BRKT-DUAL in a Custom Pocket

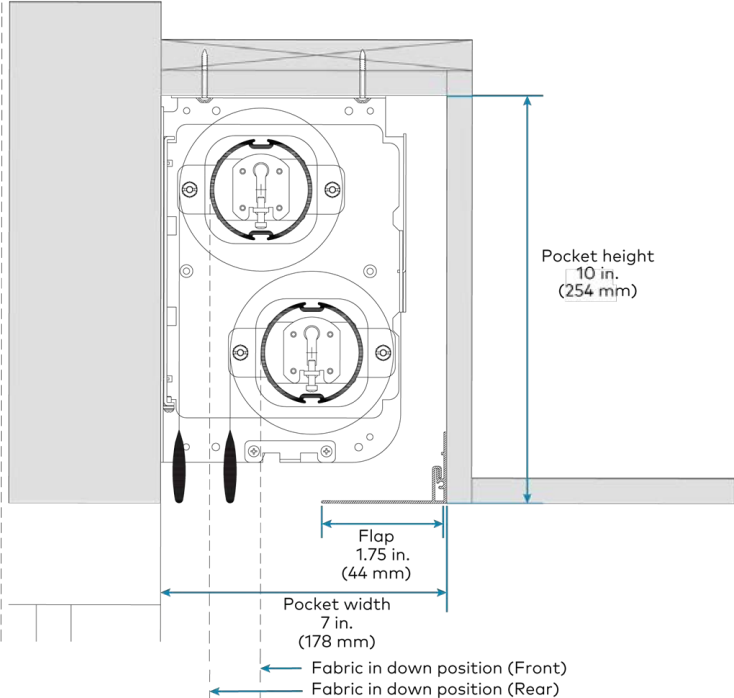

# Crestron Drapery Track

Crestron Shading Solutions (CSS) provide precise, quiet one-touch daylight management with a complete line of motorized drapery track systems. Drapery track systems add a soft, graceful touch to any décor and allow the customer to easily regulate the lighting in a room with a simple touch of a button. Draperies are energy efficient and provide UV protection, glare control, and privacy at a competitive cost.

Crestron brings the same engineering excellence from its advanced control and automation solutions to its shading product line.



Crestron drapery track offers a variety of components to assemble a roller shade that fits any application. Refer to the following sections for an overview of the available components for a Crestron drapery track:

- [Determining the Proper Drapery Track System \(on the facing page\)](#)
- [Mounting Options \(on page 52\)](#)
- [Arm Types \(on page 54\)](#)
- [Splicing \(on page 55\)](#)
- [Track Styles \(on page 56\)](#)
- [Fabric Types \(on page 59\)](#)
- [Draw Types \(on page 60\)](#)
- [Measuring Guidelines \(on page 62\)](#)
- [Dimensions \(on page 63\)](#)



# Determining the Proper Drapery Track System

Every drapery track system has a draw configuration and arm style. Draw configuration refers to the point or points on the track where the draperies are opened. Fabric can be opened using a left or right draw application. Fabric can also be opened using a center draw, asymmetric draw, or a multiple draw for spaces that require more than one opening.

Drapery fabrics are pleated into a pinch pleat or Ripplefold style to suit any décor.

Depending on their individual characteristics, drapery fabrics are pleated into one of several styles. The pinch pleat, and Ripplefold drapery styles are both supported by Crestron drapery track systems. The carriers from which the draperies hang attach to the fabric in patterns specifically designed to flatter the pleat style. The master carrier arm is also designed to complement the pleat style and draw configuration. For example, center-draw draperies with a pinch pleat often use an overlap arm where the fabric meets for an illusion of continuity

when in the closed position. Ripplefold draperies with a center draw achieve a different aesthetic with arms that butt up against one another when the draperies are closed.

**NOTE:** To cover windows wider than 32 ft (9.8 m), multiple drapery tracks should be used.



# Mounting Options

Drapery track system hardware can be mounted to a ceiling, on a wall, or inside a custom pocket (built by the customer).

## Ceiling Mount

Use cam-lock mounting brackets (CSA-DRP-CAM-LOCK) to secure the drapery track directly to the ceiling. Cam-locks have a handle that rotates to engage and secure the drapery track. In special circumstances where cam-locks cannot be used, the drapery track can be secured directly to the ceiling with screws.

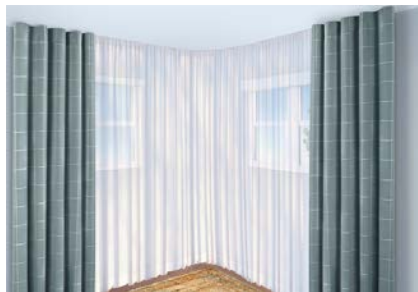

## Wall Bracket

Adjustable "L" brackets secure the drapery track system to a wall. The adjustable "L" brackets are available in single-track (CSA-DRP-BRKT) and dual-track (CSA-DRP-BRKT-DUAL) mounting configurations. Cam-locks secure the drapery track to the "L" brackets."

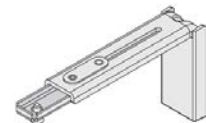

The "L" brackets can be adjusted to ensure that the drapery track is properly positioned on the wall.

**NOTE:** The "L" brackets are not intended for use in a pocket.

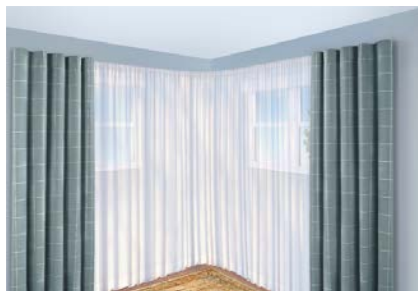

## Pocket Mount

Customer fabricated pockets can be created to fully conceal the drapery track system. The drapery track system can be mounted in a pocket using cam-lock mounting brackets or screws.

# Arm Types

Drapery track arms are available to cover a variety of different draw and fabric styles. The overlap arms prevent light from entering through the gap in the fabric. Butt arms help preserve the consistency of the Ripplefold aesthetic, although may not prevent light gaps in a center draw application."

**Center Draw Over/Underlap Arm (Pinch Pleat and Ripplefold)**

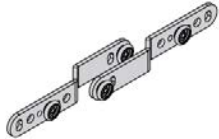

**Extended Over/Underlap Arm (Ripplefold)**

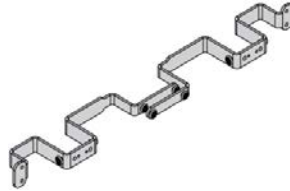

**Center Draw Butt Arm (Ripplefold)**

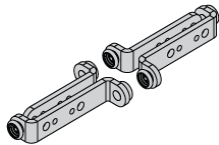

**Extended Over/Underlap Arm (Pinch Pleat)**

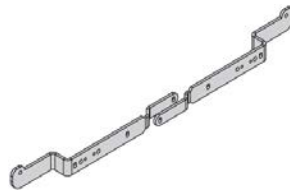

**One-Way Butt Arm (Ripplefold)**

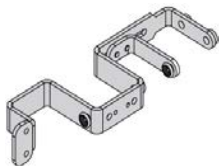

**One-way Arm (Pinch Pleat)**

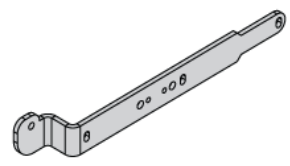

# Splicing

To provide a convenient solution for shipping and installing long drapery tracks, drapery tracks can be spliced. When a drapery track is spliced, it is shipped in shorter sections and then assembled at the installation site to create a full length track. When spliced, a drapery track can be made up to 32 ft (9.8 m) in length.

## Drapery Track Splicing Rules:

- No more than two splices should be used on one track length.
- Splices can only be made along straight sections. A minimum of 10 in. (254 mm) of straight section is required on both sides of a splice on any curved, S curved, or bent sections of a track.
- The recommended splice location for center and asymmetric draw is at the draw location. The recommended splice location for a one-way draw is furthest away from the motor.
- The maximum drapery track length is 32 ft (9.8 m) with splices.
- The maximum drapery track length without a splice is 20 ft (6 m).
- The maximum width of a drapery track shipping container is 5 ft (1.5 m). Bent and curved tracks may require additional splices to meet the shipping container constraints.

**NOTE:** Splices create a slight gap in the drapery track. As the carriers travel across the gap in the drapery track, a slight click may be heard.

# Track Styles

Crestron Drapery Tracks are available in straight track, bent track, and curved track configurations that conform to virtually any wall configuration. The Drapery Tracks are made of aluminum and available in white or brown.

Drapery Track Length	Straight Track	Single Bend	Dual Bend	Curved
0 to 20 ft (0 to 6 m)	175 lbs (79 kg)	110 lbs (50 kg)	80 lbs (36 kg)	80 lbs (36 kg)
20 to 32 ft (6 to 9.8 m)	145 lbs (66 kg)	100 lbs (45 kg)	80 lbs (36 kg)	80 lbs (36 kg)

## Straight Track

Straight track is used in most applications where the window and wall are flat and on the same plane.

## Bent Track

Bent drapery tracks can be used for bay windows, corner conditions, ect. This allows a single motor to control a drapery spanning multiple sections of straight track with intermittent 45° or 90° bends."

**NOTE:** Bent tracks have a minimum bend radius of 19 in. (483 mm).

A standard bent track uses 45° and 90° bends in the track. For nonstandard bends, submit a template that can be used by our production facility to match the layout of your room. For information on drapery track templates, refer to the [CSA-DRAPERY-TEMPLATE-KIT Instruction Guide](#) (PDF) (Doc 7821).

### Drapery Track with a 45° Bend

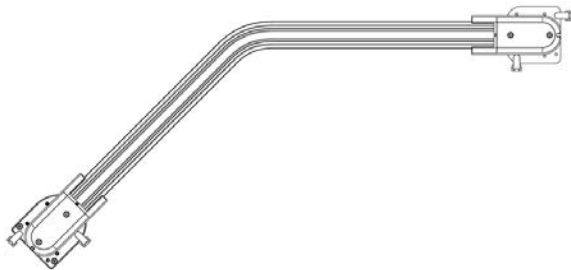

The 45° bend drapery track has a minimum bend radius of 19 in. (483 mm).

**Drapery Track with a 90° Bend**

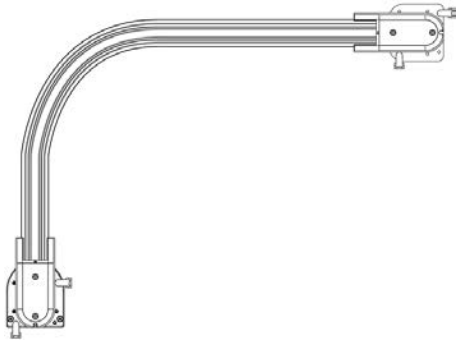

**Drapery Track with a 90° Double Bend**



**Drapery Track with a 45° Double Bend**

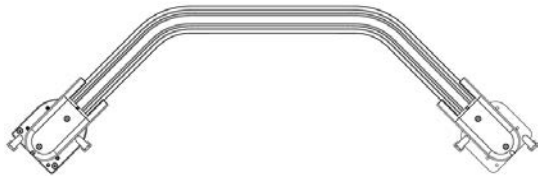

**NOTE:** Double bend tracks may incorporate a splice along the middle section for ease of shipping.

## Curved Track

Curved drapery tracks can be installed in any application that has a continuously curved window. This allows smooth coverage of a curved wall, or other applications. A standard curved track can be built in lengths up to 20 ft (6 m). Custom bends are also available.

**NOTE:** The curved drapery track has a minimum arc radius of 10 ft (3 m).

Templates are required for all curved drapery tracks. To submit a template, refer to the [CSA-DRAPERY-TEMPLATE-KIT Instruction Guide](#) (PDF) (Doc 7821).

**NOTE:** Splices are not recommended on a curved track.

### Drapery Track with a 10 ft (3 m) Arc Radius



The S Curve drapery tracks can be made only by splicing two bends together and must have a straight section at each end of the curves where they meet in order to place the splice. There must be a minimum of 10 in. (254 mm) of straight track before and after the splice in S Curve drapery tracks. The minimum radius for a continuous curve is 10 ft (3 m).

### S Curve





# Fabric Types

The fabric for Crestron Drapery Track systems is provided by your local drapery fabric supplier. Fabric can be designed to be hung using a pinch pleat style or ripplefold style.

## Pinch Pleat

The pinch pleat style has a pleated look created by a pinched, consistent gathering of fabric at the top of the drapery panel. The pin-on hooks, inserted into the back of the pleats, hang from the carriers on the drapery track.

## Ripplefold

The Ripplefold style uses snap tape sewn directly on the back of the drapery panel. The drapery panel snaps directly to the carriers on the drapery track. Snap carriers are available in 80%, 100%, or 120% fullness. The distance between the carriers strung together defines the fullness.

### Ripplefold Drapery Fullness

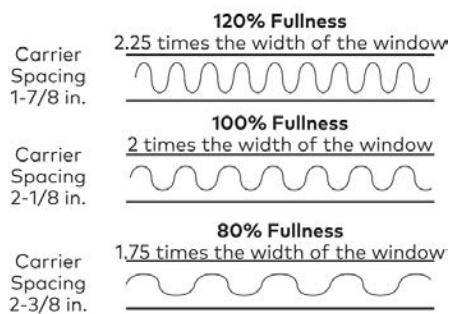

# Draw Types

Drapery track draw styles are available for almost any application or room shape. The draw configuration refers to the point or points on the track where the draperies can be opened.

- **Left Draw** - Drapery fabric opens from the right to the left. The motor is mounted on the left end of the drapery track.



- **Right Draw** - Drapery fabric opens from the left to the right. The motor is mounted on the right end of the drapery track.



- **Center Draw** - Drapery fabric opens from the middle of the drapery track. The fabric on the left travels to the left, the fabric on the right travels to the right. The motor is mounted on either the right or left end of the drapery track.

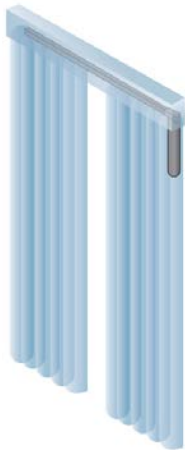

- **Dual Draw** - A left draw drapery track and a right draw drapery track are installed next to each other. Drapery fabrics open from the middle of the drapery track. The fabric on the left drapery track travels to the left, the fabric on the right drapery track travels to the right.



- **Asymmetric Draw** - Similar to center draw, but the fabric opening is not centered on the track. The fabric on the left travels to the left, the fabric on the right travels to the right. The motor is mounted on the right or left end of the drapery track.



**NOTE:** The asymmetric draw (where the drapery is wider on one side) may be more appropriate for a window that is not centered on the wall. This draw style will only fully open for the shorter distance of travel between the master carrier and the end of the track. The multiple draw may be more appropriate for one long track that is used for two individual window openings.

# Measuring Guidelines

Refer to the information below when measuring for a drapery track system:

- Measure the drapery track width at the top of the window where the drapery track system will be mounted.
- Check each window frame for level and plumb.
- To accommodate the stackback width when mounted in a pocket, the track must be centered in a space at a minimum of 6.5 in. (165 mm) wide for single tracks and 11 in. (280 mm) for dual tracks in order for the drapery to move freely.
- Drapery tracks should be mounted at least 3.5 in. (89 mm) from the wall.
- Inspect the window and the area around the window for obstructions (knobs, sills, etc.) that may block the travel of the drapery.
- Drapery stackback, typically 1/3 of the total track length, is an area that will always be covered by fabric when the drapery is open. In a center draw configuration, the 1/3 stackback will be split, with 1/6 on the left and 1/6 on the right. When possible, the drapery stackback should be positioned covering the wall adjacent to the window in question. If the stackback is going to be partially obstructing the view out the window, it is important to set this expectation with the customer.
- For a drapery track that measures greater than 20 ft (6 m) in length, a splice is required. A splice is when one long track is broken up into two or more shorter tracks. For more information on drapery track splicing, refer to [Splicing \(on page 55\)](#).
- If using an asymmetric draw drapery track, consider the drapery track location. An asymmetric draw is when the drapery is wider on one side. For more information, [Draw Types \(on page 60\)](#).
- If a curved or bent drapery track is to be used, refer to [Track Styles \(on page 56\)](#) and to the [CSA-DRAPERY-TEMPLATE-KIT Instruction Guide](#) (PDF) (Doc 7821).

For more information, refer to the [Shade Measuring Worksheet: Drapery System](#) (PDF) (Doc. 7922) located on the CSS web page.

# Dimensions

The dimensions for parts of the Drapery Track system are shown in the following illustrations.

## Arm Dimensions

### Center Draw Over/Underlap Arm

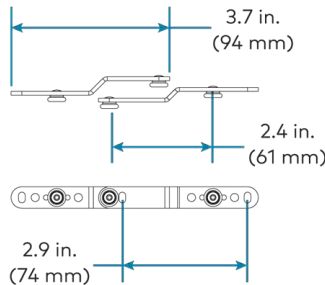

### Center Draw Butt Arm (Ripplefold)

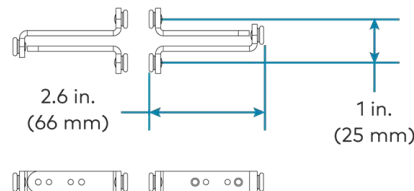

### One-Way Arm (Pinch Pleat)

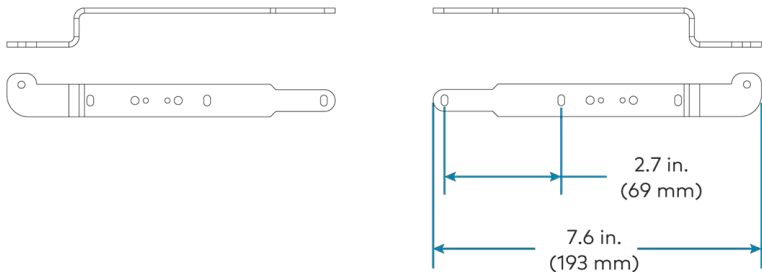

### One-Way Butt Arm (Ripple Fold)

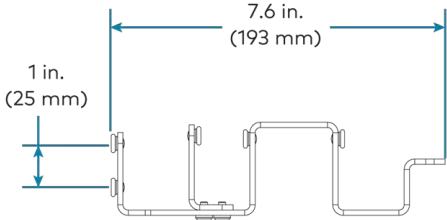

### Extended Over/Underlap Arm (Ripple Fold)

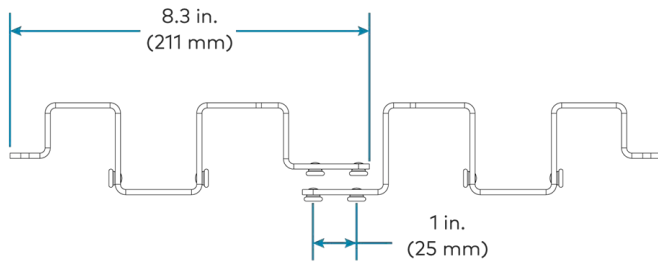

**NOTE:** The Extended Over/Underlap Arm (Ripple Fold) will extend 0.7 in. (18 mm) past the end of the drapery track.

### Extended Over/Underlap Arm (Pinch Pleat)

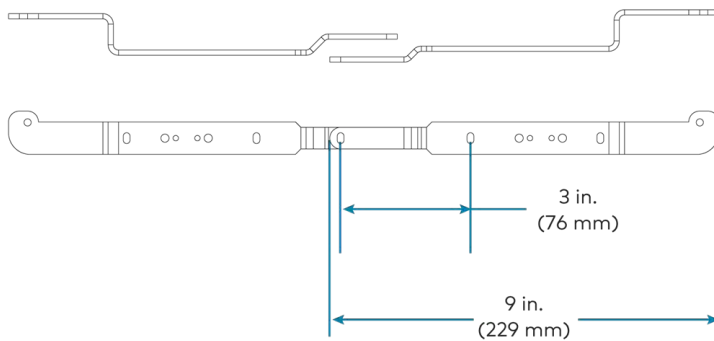

**NOTE:** The Extended Over/Underlap Arm (Pinch Pleat) will extend 1.5 in. (38 mm) past the end of the drapery track.

# Drapery Track Ceiling Mount Configurations

This section provides several different types of ceiling mounted drapery tracks.

## One Way Pinch Pleat Arm Ceiling Mount Drapery Track - Top and Front Views

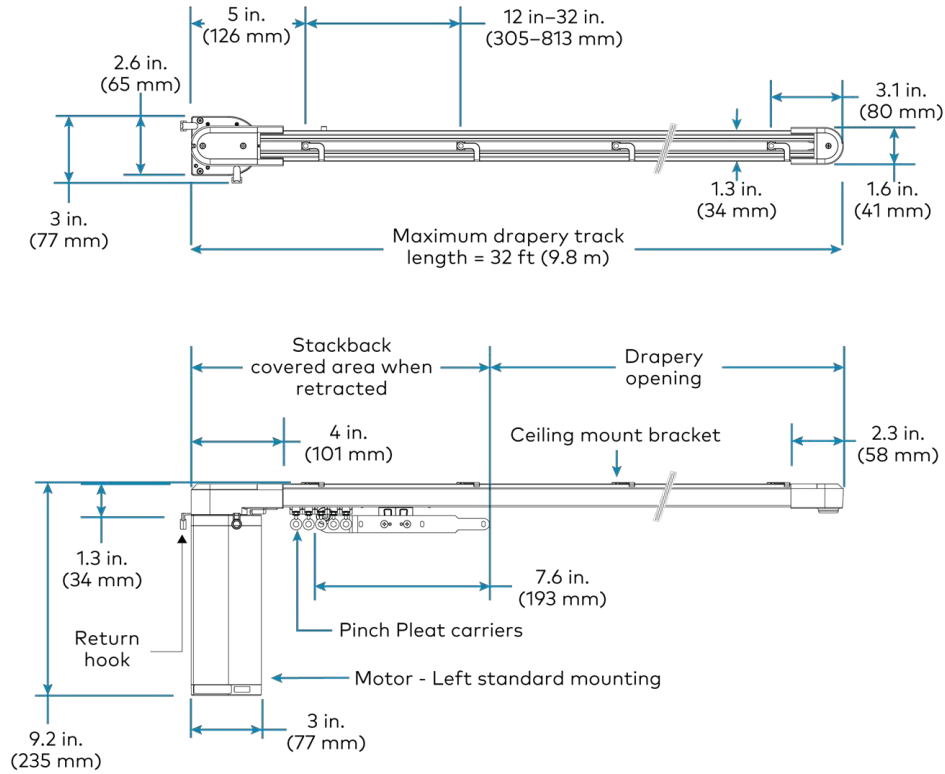

**NOTE:** Additional brackets may be required in the stackback area under heavy load conditions.

### One Way Ripplefold Butt Arm Ceiling Mount Drapery Track - Top and Front Views

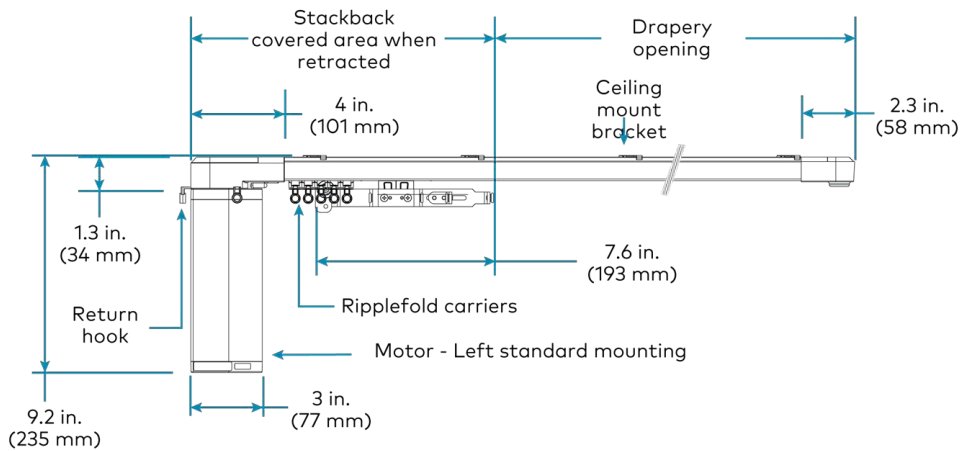
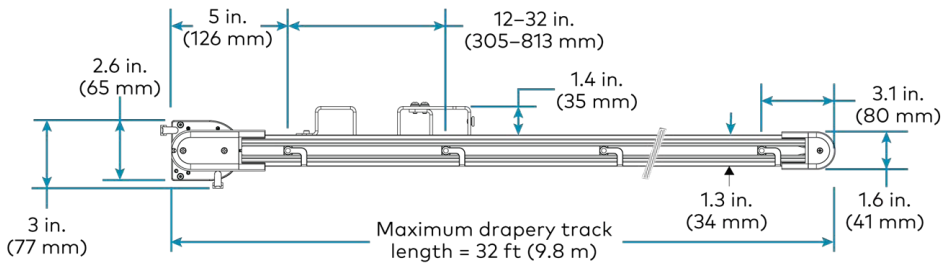

**NOTE:** Additional brackets may be required in the stackback area under heavy load conditions.



### Center Draw Pinch Pleat Arm Ceiling Mount Drapery Track - Top and Front Views

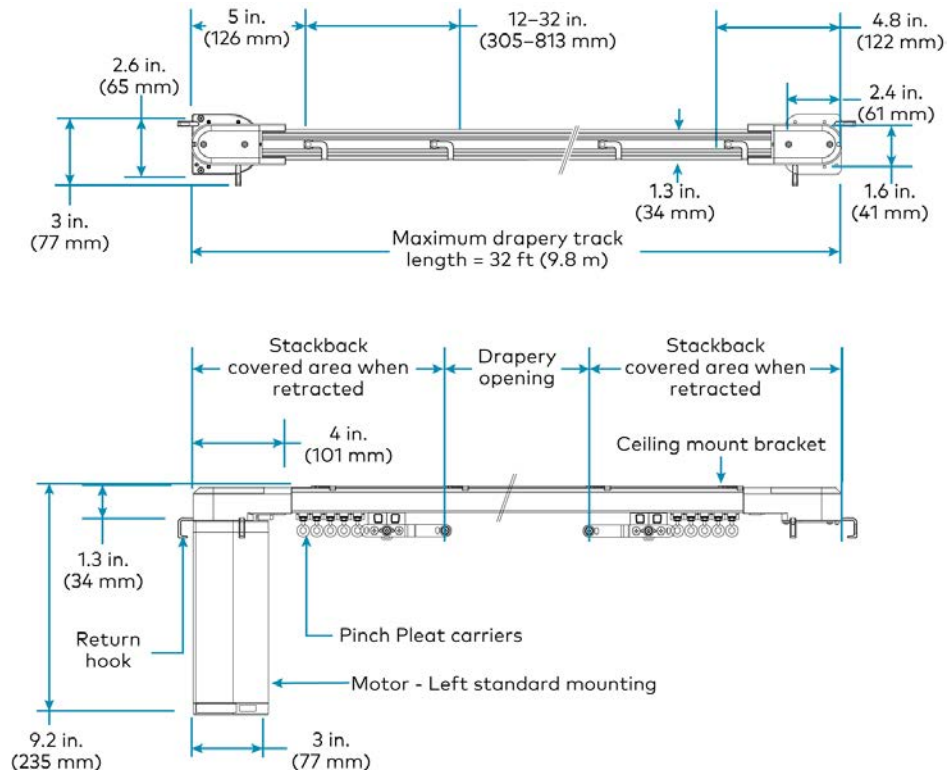

**NOTE:** Additional brackets may be required in the stackback area under heavy load conditions.

### Center Draw Ripplefold Butt Arm Ceiling Mount Drapery Track - Top and Front Views

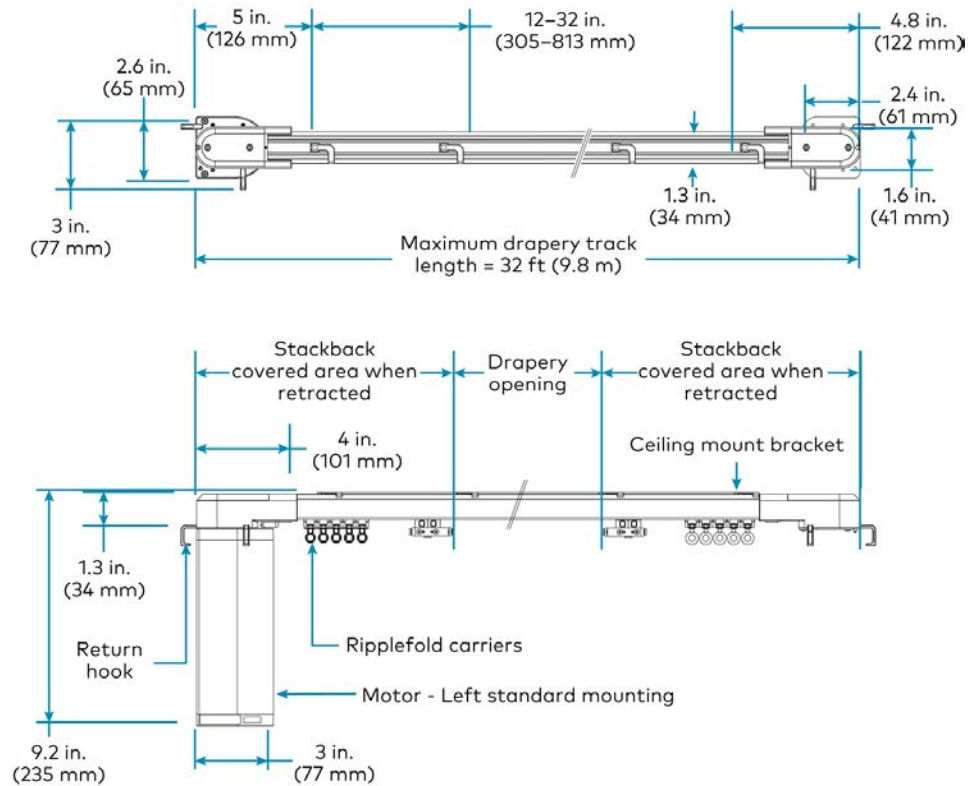

**NOTE:** Additional brackets may be required in the stackback area under heavy load conditions.

# Drapery Track Wall Mount Configurations

This section provides several different types of wall mounted drapery tracks.

## One Way Pinch Pleat Wall Mount Drapery Track - Top and Front Views

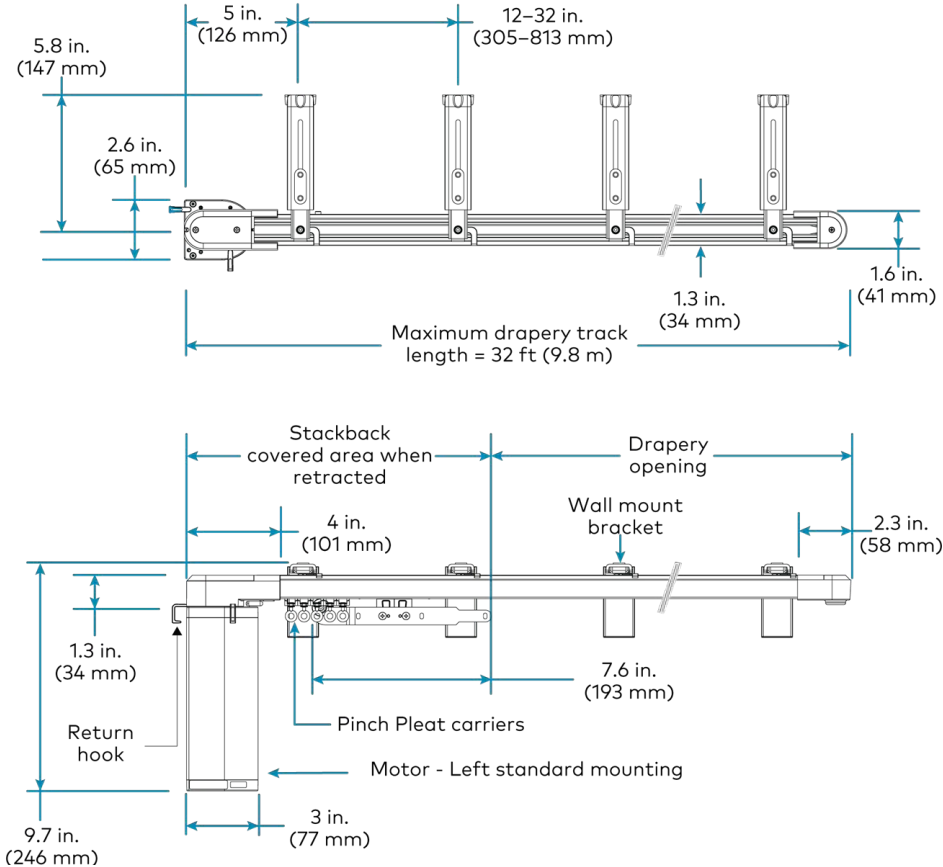

**NOTE:** Additional brackets may be required in the stackback area under heavy load conditions.

### One Way Ripplefold Butt Arm Wall Mount Drapery Track - Top and Front Views

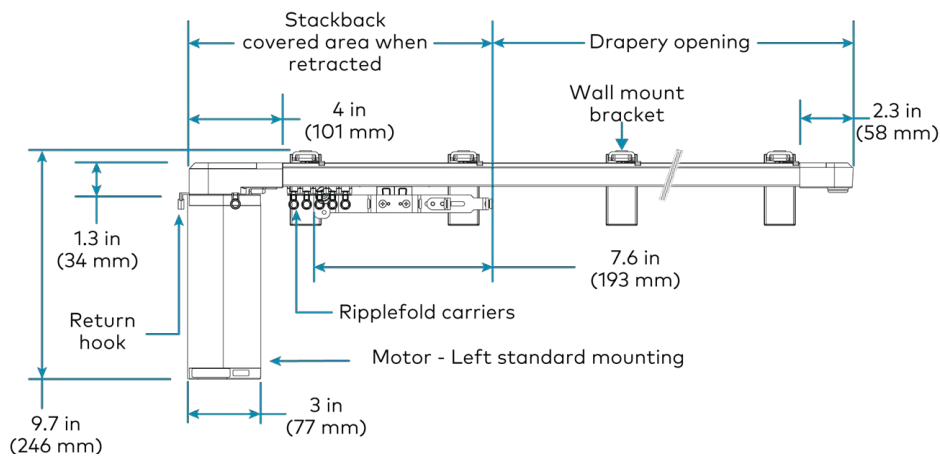
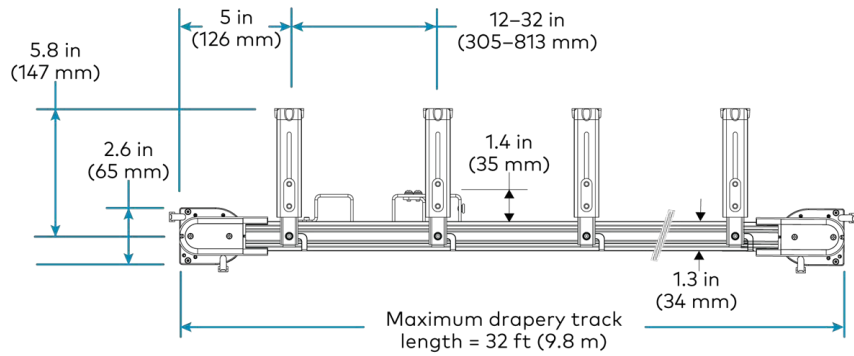

**NOTE:** Additional brackets may be required in the stackback area under heavy load conditions.

### Center Draw Pinch Pleat Arm Wall Mount Drapery Track - Top and Front Views

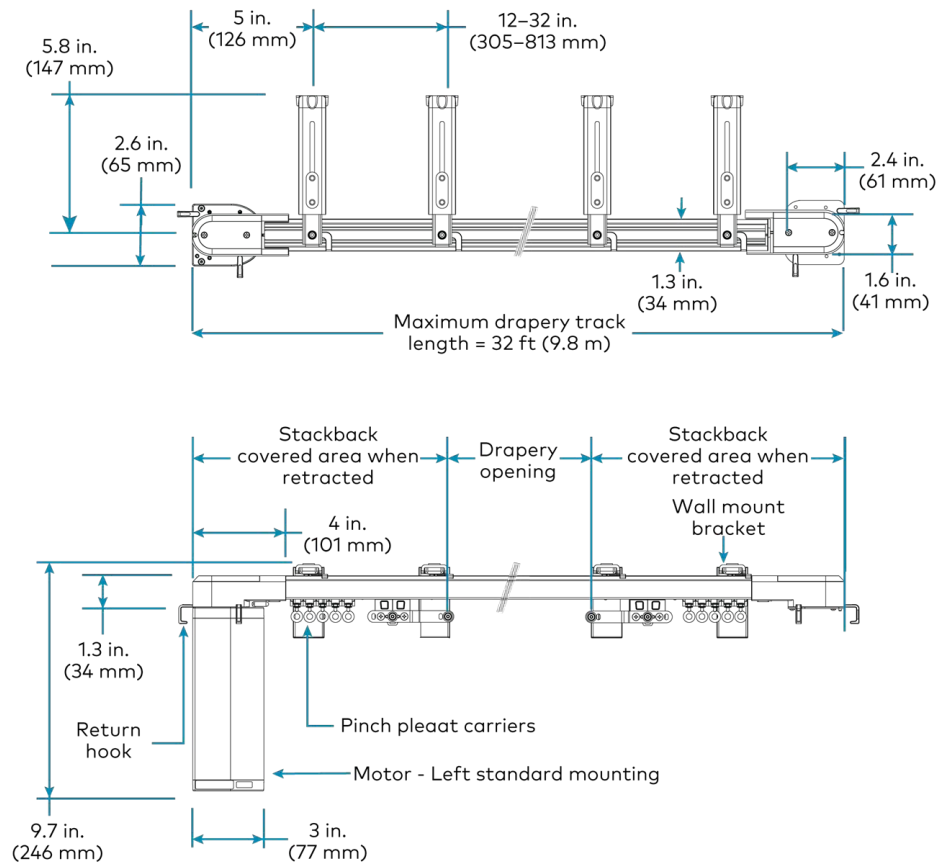

**NOTE:** Additional brackets may be required in the stackback area under heavy load conditions.

### Center Draw Ripplefold Butt Arm Wall Mount Drapery Track - Top and Front Views

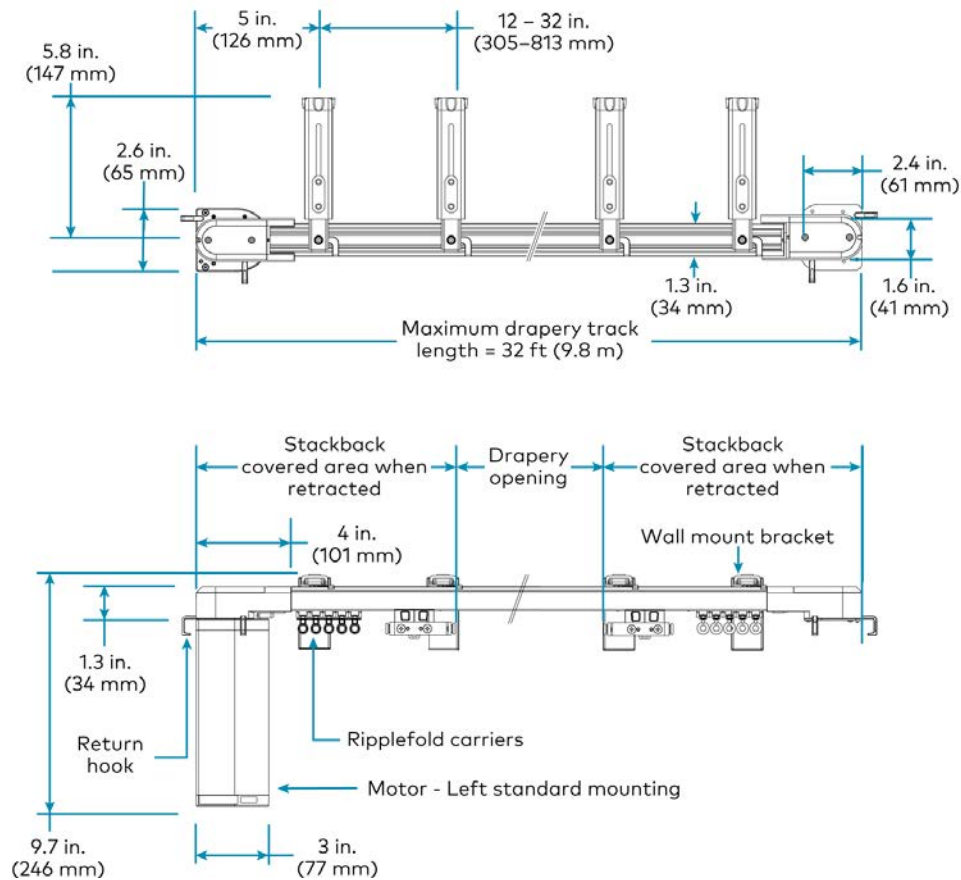

**NOTE:** Additional brackets may be required in the stackback area under heavy load conditions.

### Dual Spacing Wall Mount Drapery Track

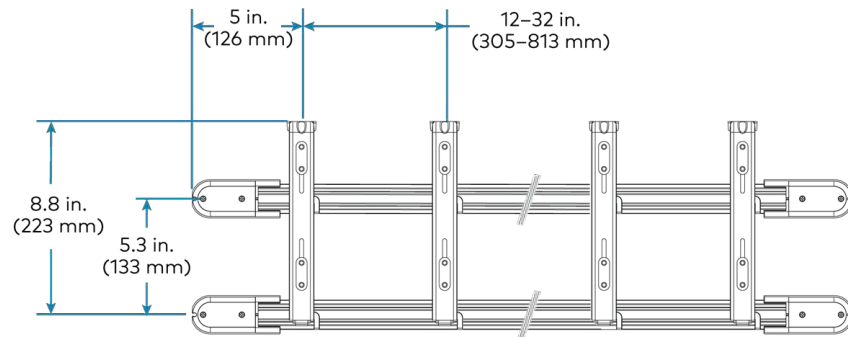

**NOTE:** Additional brackets may be required in the stackback area under heavy load conditions.

# Designing and Specifying

When designing or specifying a Crestron shade or drapery track system, adhere to the following:

- Do not take the final window measurements until the trim is installed and construction around the windows is complete.
- Measure the width of the shade or drapery track system where it will be mounted (top of window). It is likely that the window frame is not perfectly square, so be sure to measure the top, middle, and bottom widths of the window frame.
- Make sure that there is blocking behind the location where the shades and drapery track system will be mounted, or make note of the type of shade mounting surface, so that the installer can plan to bring the appropriate fasteners.
- Talk to the owner or designer when outside mounting a shade, if the window has trim decide whether to cover the trim completely with fabric, half of it, or any other portion.
- Take into consideration obstructions in the window opening, and above and below the window (crank handles, baseboards, and tilting windows, etc.) to ensure that the shade does not snag while moving.
- Take note of HVAC ductwork. Air blowing directly on a shade or drapery track system may affect performance. Prolonged exposure to heat may also damage the fabric.
- Verify that the usable roll width of the selected fabric can accommodate the window size.
- Verify that the selected bracket will fit in the jamb or pocket that is specified.

# Programming

When programming Crestron shades or drapery track systems, adhere to the following:

- Be sure that shade or drapery track system motors are running on the most recent Crestron firmware.
- Use dedicated Open and Close buttons to control shades or drapery track systems. The first press of the button sends the shade or drapery track system to the open or closed limit. A second press of the button stops the shade or drapery track system.
- Check if button real estate is at a premium at the location, and if so use a single button for control. An Open/Stop and Close/Stop control is how a typical garage door opener works and easily understandable.
- Do not control shades that are not in view, because there may be an object left on a windowsill or another obstruction that prevents the shade or drapery track system from moving freely. This could result in damage to the fabric, or damage to the obstruction.



# Wiring and Power

Use Cresnet cable and Crestron power supplies when installing and connecting shades and drapes. Refer to the following wiring and power supply options.

## Wiring

- Use Cresnet cable for power and communication.
- The maximum Cresnet cable length between the power supply and a QMT shade and drape motor:
  - **Cresnet Cable:** 130 ft (39.5 m) maximum.
  - **Cresnet HP Cable:** 500 ft (152 m) maximum.
- Each QMT shade and drape motor requires a dedicated power supply output.
  - Do not daisy-chain QMT shade and drape motors.
  - The QMT shade and drape motor must be home-run from the power supply.

## Power Supplies

Use a Crestron power supply to power Crestron QMT Shade and Drape motors. Crestron offers a single-motor power supply and a ten-motor power supply.

### Single-Motor Power Supply

The Crestron [CSA-PWS40](#) (domestic) and [CSAI-PWS40](#) (international) are outlet-mountable power supplies that provide power for a QMT Shade or Drape motor. Single-motor power supplies are especially useful when providing power from a local outlet to an infiNET EX wireless motor.



## Ten-Motor Power Supply

The [CSA-PWS10S-HUB-ENET](#) Power Supply powers up to 10 (home run) Crestron Shade or Drape motors with independent connections. There are five communication segments which handle two motors each. System communication options are Ethernet or Cresnet. Multiple power supplies can be daisy chained with Cresnet. There is a recommended maximum of three CSA-PWS10S-HUB-ENET power supplies per Ethernet connection to minimized potential latency.



# Ordering Guidelines

When ordering Crestron shades or drapery track systems, adhere to the following:

- Do not order shades or drapery track systems before it is necessary, as they can be damaged if left lying around. Shades and drapery track systems are typically the last technology to install.
- Measure multiple times and take the final measurements after all trim work and painting is complete.
- Review the window for deductions on inside mount shades in the Crestron Design Tool (CDT). Either use CDT, or calculate the deductions yourself before entering the dimensions.
- Order fascia and the top and back cover separately and at a longer length than required so that the metal extrusions can be cut on-site for a perfect fit.

# Installation Guidelines

When installing Crestron shades or drapery track systems, note the following:

- Do not install shades or drapery track systems when construction is still in progress. If it is absolutely necessary to perform shade or drapery track system installation work while construction is in progress:
  - Leave the paper wrapping on the package.
  - Mount all brackets and terminate wires with connectors.
  - Install the shade or drape fabric after construction is complete. Mounting the fabric and making power and data connections is a fast process that only takes a few minutes.
- Make sure that the painting at the location is complete to avoid getting paint on the shade fabric.
- For optimal performance, mount shades and drapery track systems so that they are level.
- To ensure a perfect fit when installing shades with Crestron fascia that is provided with the shade:
  1. Secure the brackets to the fascia and then hold the bracket and fascia assembly in the desired installation location.
  2. Mark the location of both brackets.
  3. Remove the bracket from the fascia and then mount the brackets.
- For wall-mount applications, thick trim may require shimming the bracket away from the wall or reversing the roll of the shade so that the fabric does not contact the trim.
- Properly dress all wiring. Wires or connectors that make contact with the shade tube or fabric will make noise and potentially damage the fabric.
- After the shade is hung:
  - The factory set defaults will likely need to be adjusted. Do not raise or lower the shade without being able to monitor the shade. If necessary, someone needs to be in front of the shade with the ability to stop the motor.
  - Check for telescoping. The first time the shade travels up after installation is the most critical time to verify the shade is traveling straight. Telescoping is adjusted at the factory, but may still occur if the shade is not level. It is important to fix the problem before damage to the fabric occurs. All Crestron shade brackets have adjustments built in to minimize telescoping, but sometimes shim tape may need to be used.
  - Check the shade for frayed edges and, if necessary, trim the frays. Frayed edges are not a manufacturing defect. Fraying occurs from handling shades and is most common with PVC coated fiberglass fabrics.
- Return to the work site after 30 and 90 days to check limits, telescoping, and trim frayed edges.

# Shipping and Receiving Shades

When shipping and receiving Crestron shades or drapery track systems, adhere to the following:

- The maximum box length sent via UPS is limited. If the shade or drapery track system is more than 92 in. long, shipping via motor freight is necessary. In most cases, this means the products cannot ship overnight. In cases where it is possible to ship overnight, the shipping fees may be cost prohibitive.
- When shades or drapery track systems are shipped to or received at a home that is under construction, a semitruck may not be able to deliver to the house. The truck may need to be met at the street.
- Remember that someone needs to be present at the shipping location to receive the shades.
- If there are several shades delivered on a pallet, be prepared to use a forklift to get the shades off the truck. If a forklift is not available at the time of delivery, it may be necessary to break the pallet down by hand to unload the cartons off the truck. If lift gate service is required, please let Shade Support know when placing the order.
- Do not stand shade cartons on the ends; this could wrinkle or damage the fabric.
- Splices can be used to split drapery tracks for shipping purposes.
- Check to be sure that long shades or drapery track systems can be maneuvered around the location. Remember that shades or drapery track systems may not fit in elevators or up staircases.
- Install the shades within 2-3 weeks of receipt. Keeping the shades in their original cartons may create impressions on the fabric. Impressions typically "hang out" over time when the shade is hung in the window or can be coaxed with a hair dryer.

# Fabric Care and Maintenance

## How to Clean Fabric

Refer to the care instructions for the fabric to determine the appropriate cleaning methods. Consult a reputable dry cleaner when fabric requires dry cleaning.

## Roller Shade Fabric Edge Fray

Some shading fabrics are manufactured using PVC coated fiberglass yarns. During the cutting process the PVC coating is melted together on the shade edges. Inevitably, some fiberglass strands may not be completely sealed. Over time, the fiberglass strands can fray slightly and become noticeable. Simply trim away frayed fibers.

While the bigger more noticeable frays are trimmed by the manufacturer at the factory, smaller frays can reappear during shipping, installation, or over time from daily operation. But don't worry, with a pair of scissors this is an easy problem to fix. With your fingers, fluff the fabric edge so that all frays are visible, then simply trim them away with your scissors.

## Detailing the Cut Edges

Primarily noticeable on dark fabrics, white fiberglass yarns may be visible even after you've trimmed the frayed edges. With a permanent marker you can easily color the white fiber ends so they blend in with the fabric. For best results use a quick drying marker. Black, brown, or gray markers generally blend in best with most dark fabrics.

If you have a two-colored fabric, make sure to select a marker color that matches the lighter colored fabric. Test a hidden spot first to ensure that the colors match. To prevent markers from bleeding onto the fabric and staining the edge of the shade, go slowly and handle your markers with care.

## Minimizing Fraying

It's important to give your shades a clear path in which to operate. By keeping your shade fabric from rubbing on other objects, unwanted fraying can be minimized or prevented. Telescoping, as mentioned above, can also increase fraying - particularly when the fabric edge starts rubbing against the shade brackets.

# Glossary

## Deflection:

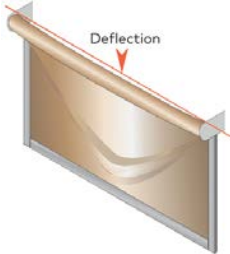

As a shade increases in width, the metal tube begins to sag due to the diameter of the tube and the weight of the fabric.

## "V" or "V-ing", "A" or "A-ing":

When deflection is present in the tube, the fabric sags and produces a "V" or "A" shape typically in the center of the shade.

## Ripple/Wave:

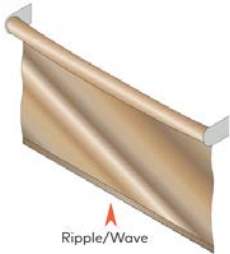

Vertical ripples in the fabric. Ordering shades with battens can help minimize this effect.

## Curling/Cupping:

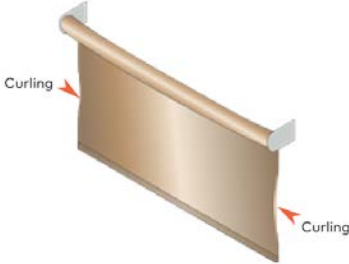

The edges of the fabric panel curl. It starts out normal at the top near the tube, becomes more pronounced toward the middle of the panel, and then lessens as it gets closer to the hembar. Ordering shades with battens can help minimize this effect.

**Twisting:**

Typically visible on tall and narrow shades where the fabric twists vertically.

**Telescoping:**

The tendency for a shade fabric to not roll up perfectly square with the shade tube. The fabric will telescope to the right or left and hang over the side of the tube. All shades are adjusted at the factory to ensure proper tracking. Actual installation conditions may prevent the shade from tracking properly. The levelness of the mounting surface is the most common cause of telescoping.



# Resources

The following resources are provided for the Crestron Shading Solutions.

**NOTE:** You may need to provide your Crestron.com web account credentials when prompted to access some of the following resources.

## Crestron Support and Training

- [Crestron True Blue Support](#)
- [Crestron Resource Library](#)
- [Crestron Online Help \(OLH\)](#)
- [Crestron Training Institute \(CTI\) Portal](#)

## Programmer and Developer Resources

- [help.crestron.com](http://help.crestron.com): Provides help files for Crestron programming tools such as SIMPL, SIMPL#, and Crestron Toolbox™ software
- [developer.crestron.com](http://developer.crestron.com): Provides developer documentation for Crestron APIs, SDKs, and other development tools

## Product Certificates

To search for product certificates, refer to [support.crestron.com/app/certificates](http://support.crestron.com/app/certificates).

## Related Documentation

- [Crestron Design Tool Shades \(CDTS\)](#)
- [CS-SHADE-ROLLER-BATT](#)
- [CS-SHADE-ROLLER-CABLEGUIDED](#)
- [CS-SHADE-ROLLER-HSHEER](#)
- [CSA-DRAPERY-TEMPLATE-KIT](#)
- [CSA-PWS10S-HUB-ENET](#)
- [CSA\(I\)-PWS40](#)

- [Shade Measuring Worksheet Drapery System](#)
- [Shade Measuring Worksheet Single roller and In-line Coupled](#)

This page is intentionally left blank.

